

Job Name: 25-2649 - The Laurel Assisted Living Facility  
 Job Location: Bowling Green, KY  
 Contractor: Infinity Pipeline, Inc.

Plant: Beaver Dam, KY  
 10/24/2025 7:27:40 AM

Tech: K. Cardwell  
 PC: E. Bradley



**Structure ID: LS-8**

**P1 MH048BAVF**

**MH BASE Custom Ht F/n**

- P3) 24" x 36" - CASTING HEIGHT - 6"
- P2) 48" - MH FLAT TOP w/24"x36" Hole F/F - 7"
- P1) 48" - MH BASE Custom Ht F/n - 35"
- 1) CASTING - HOE 470 SET LV (F/G/H)
- 1) 48" - Conseal CS-102 1.00"
- 1) 24" x 36" - Conseal CS-102 1.00"
- 1) Hole - 30
- 1) Hole - 24
- 3) MH Step ML-10-TDS-NCR - 10"

0 lb  
 1044 lb  
 3262 lb  
 394 lb  
 0 lb  
 0 lb  
 0 lb  
 0 lb  
 0 lb  
 0 lb  
 Structure Total: 4700 lb

- Structure Notes:**
1. PER ASTM C-478 SPECS
  2. CONCRETE: 4,500 PSI AT 28 DAYS
  3. REINFORCEMENT: PER ASTM A615
  4. STEPS AT 120 DEGREES
  5. HOE 470 FRAME, L-VANE GRATE, & CURB HOOD SUPPLIED BY ICAST

Rim: 549.55' Rim to Invert: 4.05' Slack: 2.5" Sump: 1.9" Step Position: 120°

Position	Elev	Angle	Ext. (cw)	Pipe	Pipe OD	Connector	Hole	Horz Size	Up (↓)	Offset
Invert 1	545.5'	0°	0"	24" HDPE	27.8"	Hole 30	30"	32.406"	0"	0"
Invert 2	545.5'	208°	105.278"	18" HDPE	21.2"	Hole 24	24"	25.133"	0.3"	0"
Invert 3										
Invert 4										
Invert 5										
Invert 6										
Invert 7										
Invert 8										

RIGHT-SIDE UP VIEW (int. dimensions)

UPSIDE-DOWN VIEW (int. dimenions)

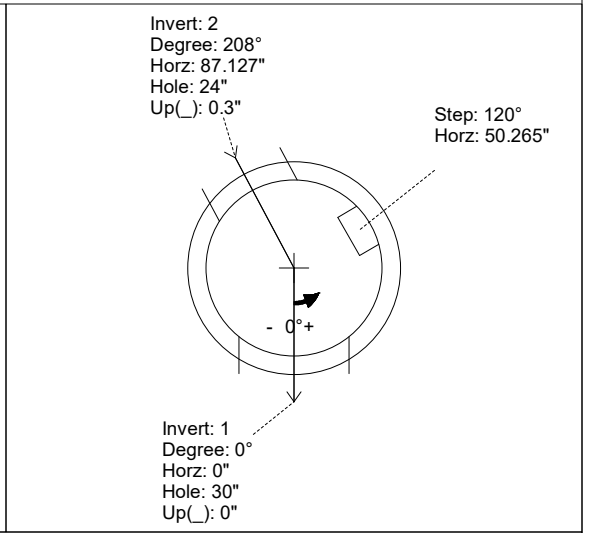
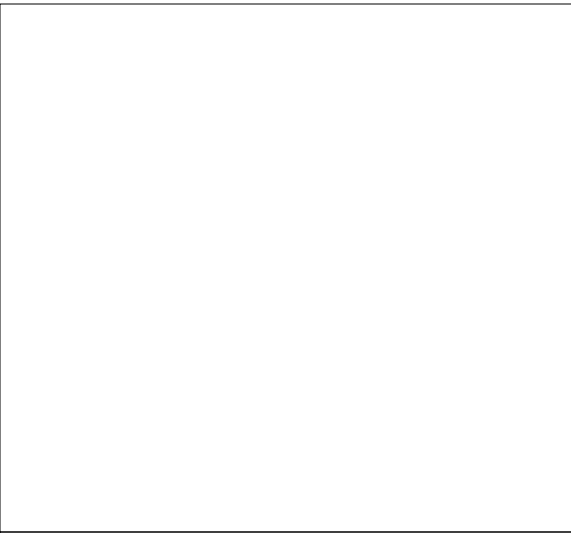
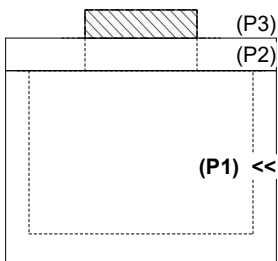

INSIDE WALL DIMENSIONS

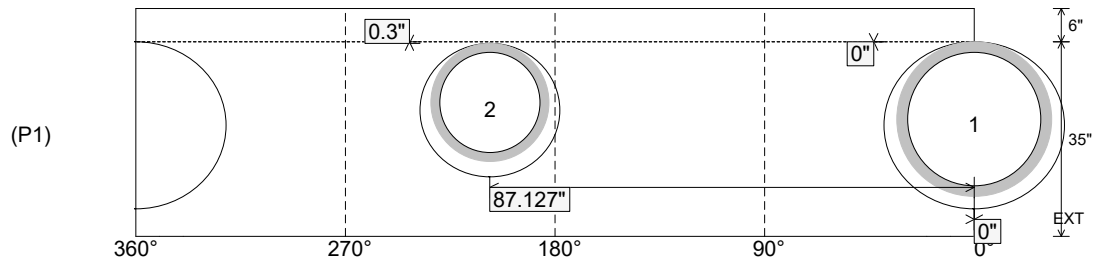

Coating (Int):  
 Coating (Ext):

Seam Up: Flat  
 Seam Dn: n/a

Wall Thickness: 5"  
 Floor Height: 6"

Height (Int): 35"  
 Height (Ext): 41"

Weight (Net): 3262 lb  
 Volume (Net): 0.83cu.yd