

Job Name: 25-2649 - The Laurel Assisted Living Facility
 Job Location: Bowling Green, KY
 Contractor: Infinity Pipeline, Inc.

Plant: Beaver Dam, KY
 10/24/2025 7:27:39 AM

Tech: K. Cardwell
 PC: E. Bradley



Structure ID: LS-6

P1 MH048BA54

MH BASE T/n

- P4) 24" x 36" - CASTING HEIGHT - 6"
- P3) 24" x 36" - GRADE RING F/F - 3"
- P2) 48" - MH FLAT TOP w/24"x36" Hole F/G - 12"
- P1) 48" - MH BASE T/n - 54"
- 1) CASTING - HOE 470 SET LV (F/G/H)
- 1) 48" - Conseal CS-102 1.00"
- 2) 24" x 36" - Conseal CS-102 1.00"
- 2) Hole - 30
- 1) Hole - 20
- 4) MH Step ML-10-TDS-NCR - 10"

- Structure Notes:**
1. PER ASTM C-478 SPECS
 2. CONCRETE: 4,500 PSI AT 28 DAYS
 3. REINFORCEMENT: PER ASTM A615
 4. STEPS AT 90 DEGREES
 5. HOE 470 FRAME, L-VANE GRATE, & CURB HOOD SUPPLIED BY ICAST
 6. INVERT 3 OFFSET 11" FROM CENTER

Structure Total: 6316 lb

Rim: 550.61' Rim to Invert: 6.32' Slack: 2.74" Sump: 1.9" Step Position: 90°

Position	Elev	Angle	Ext. (cw)	Pipe	Pipe OD	Connector	Hole	Horz Size	Up ()	Offset
Invert 1	544.29'	0°	0"	24" HDPE	27.8"	Hole 30	30"	32.406"	0"	0"
Invert 2	544.29'	180°	91.106"	24" HDPE	27.8"	Hole 30	30"	32.406"	0"	0"
Invert 3	545'	227°	126.177"	15" HDPE	17.6"	Hole 20	20"	24.57"	9.12"	11"
Invert 4										
Invert 5										
Invert 6										
Invert 7										
Invert 8										

RIGHT-SIDE UP VIEW (int. dimensions)

UPSIDE-DOWN VIEW (int. dimensions)

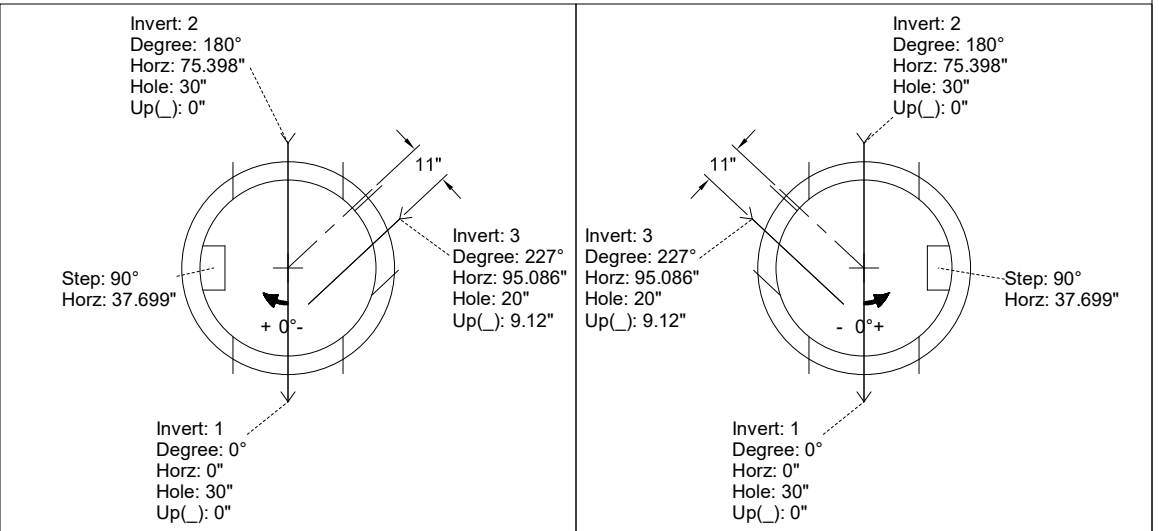
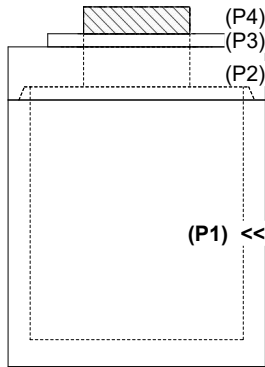

INSIDE WALL DIMENSIONS

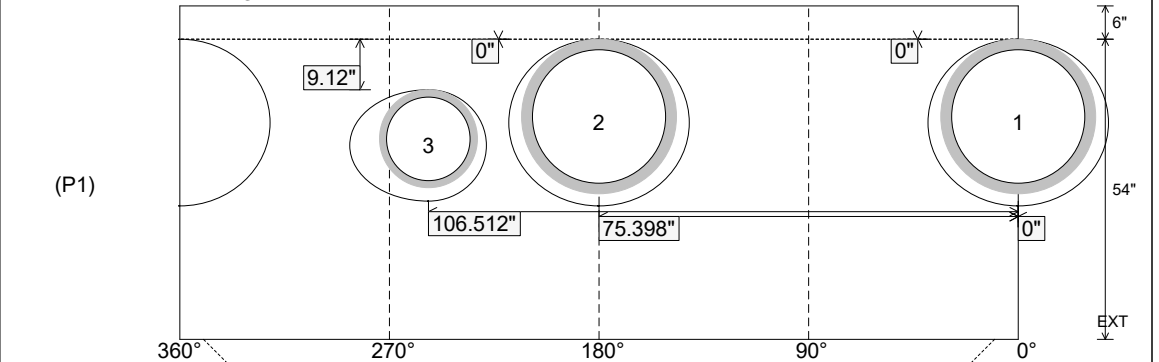

Coating (Int): Coating (Ext):	Seam Up: Tongue Seam Dn: n/a	Wall Thickness: 5" Floor Height: 6"	Height (Int): 54" Height (Ext): 60"	Weight (Net): 4315 lb Volume (Net): 1.1cu.yd
----------------------------------	---------------------------------	--	--	---