

Job Name: 25-2649 - The Laurel Assisted Living Facility
 Job Location: Bowling Green, KY
 Contractor: Infinity Pipeline, Inc.

Plant: Beaver Dam, KY
 10/24/2025 7:27:38 AM

Tech: K. Cardwell
 PC: E. Bradley



Structure ID: LS-5

P1 MH048BAVF

MH BASE Custom Ht T/n

- P3) 24" x 36" - CASTING HEIGHT - 6"
- P2) 48" - MH FLAT TOP w/24"x36" Hole F/G - 12"
- P1) 48" - MH BASE Custom Ht T/n - 67"
- 1) CASTING - HOE 470 SET LV (F/G/H)
- 1) 48" - Conseal CS-102 1.00"
- 1) 24" x 36" - Conseal CS-102 1.00"
- 2) Hole - 30
- 1) Hole - 16
- 5) MH Step ML-10-TDS-NCR - 10"

0 lb
 1300 lb
 5293 lb
 394 lb
 0 lb
 0 lb
 0 lb
 0 lb
 0 lb
 0 lb
 0 lb
 Structure Total: 6987 lb

- Structure Notes:**
1. PER ASTM C-478 SPECS
 2. CONCRETE: 4,500 PSI AT 28 DAYS
 3. REINFORCEMENT: PER ASTM A615
 4. STEPS AT 290 DEGREES
 5. HOE 470 FRAME, L-VANE GRATE, & CURB HOOD SUPPLIED BY ICAST

Rim: 550.98' Rim to Invert: 7.11' Slack: 2.22" Sump: 1.9" Step Position: 290°

Position	Elev	Angle	Ext. (cw)	Pipe	Pipe OD	Connector	Hole	Horz Size	Up (↓)	Offset
Invert 1	543.87'	0°	0"	24" HDPE	27.8"	Hole 30	30"	32.406"	0"	0"
Invert 2	543.87'	116°	58.713"	24" HDPE	27.8"	Hole 30	30"	32.406"	0"	0"
Invert 3	546.5'	202°	102.241"	12" HDPE	14.5"	Hole 16	16"	16.312"	32.21"	0"
Invert 4										
Invert 5										
Invert 6										
Invert 7										
Invert 8										

RIGHT-SIDE UP VIEW (int. dimensions)

UPSIDE-DOWN VIEW (int. dimensions)

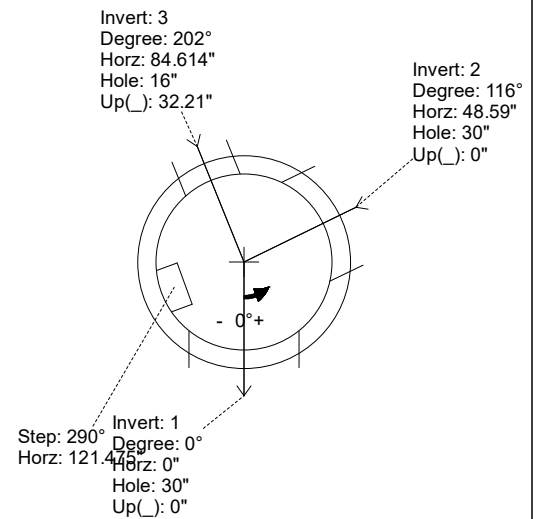
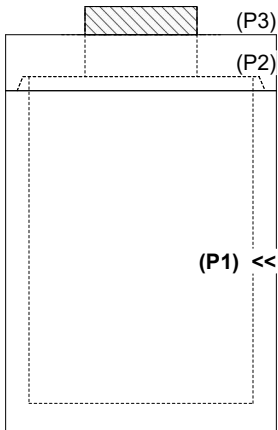

INSIDE WALL DIMENSIONS

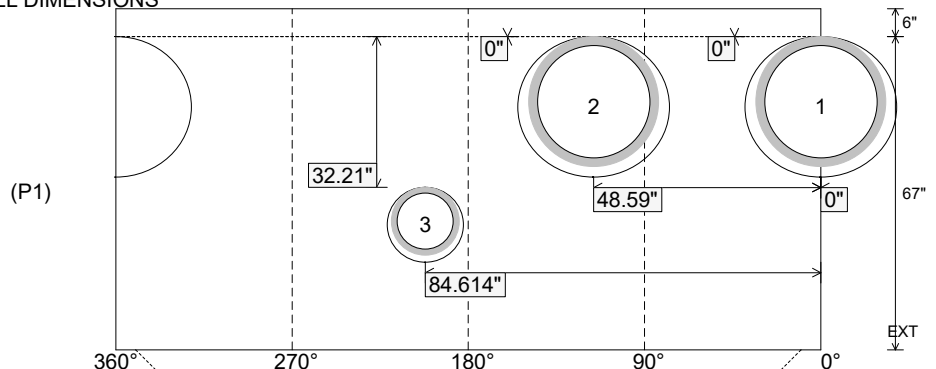

Coating (Int):
 Coating (Ext):

Seam Up: Tongue
 Seam Dn: n/a

Wall Thickness: 5"
 Floor Height: 6"

Height (Int): 67"
 Height (Ext): 73"

Weight (Net): 5293 lb
 Volume (Net): 1.35cu.yd