

Job Name: 25-2649 - The Laurel Assisted Living Facility  
 Job Location: Bowling Green, KY  
 Contractor: Infinity Pipeline, Inc.

Plant: Beaver Dam, KY  
 10/24/2025 7:27:38 AM

Tech: K. Cardwell  
 PC: E. Bradley



**Structure ID: LS-4**

**P1 MH048BA72**

**MH BASE T/n**

- P3) 18" x 18" - CASTING HEIGHT - 4"
- P2) 48" - MH FLAT TOP w/18"x18" Hole F/G - 12"
- P1) 48" - MH BASE T/n - 72"
- 1) CASTING - HOE 165A F/G
- 1) 48" - Conseal CS-102 1.00"
- 1) 18" x 18" - Conseal CS-102 1.00"
- 2) Hole - 30
- 1) Hole - 24
- 6) MH Step ML-10-TDS-NCR - 10"

0 lb  
 2334 lb  
 5531 lb  
 138 lb  
 0 lb  
 0 lb  
 0 lb  
 0 lb  
 0 lb  
 0 lb  
 Structure Total: 8003 lb

- Structure Notes:**
1. PER ASTM C-478 SPECS
  2. CONCRETE: 4,500 PSI AT 28 DAYS
  3. REINFORCEMENT: PER ASTM A615
  4. STEPS AT 90 DEGREES
  5. HOE 165-A FRAME & GRATE SUPPLIED BY ICAST

Rim: 551.05' Rim to Invert: 7.35' Slack: 2.1" Sump: 1.9" Step Position: 90°

Position	Elev	Angle	Ext. (cw)	Pipe	Pipe OD	Connector	Hole	Horz Size	Up ( )	Offset
Invert 1	543.7'	0°	0"	24" HDPE	27.8"	Hole 30	30"	32.406"	0"	0"
Invert 2	543.7'	186°	94.143"	24" HDPE	27.8"	Hole 30	30"	32.406"	0"	0"
Invert 3	546'	268°	135.647"	18" HDPE	21.2"	Hole 24	24"	25.133"	27.9"	0"
Invert 4										
Invert 5										
Invert 6										
Invert 7										
Invert 8										

RIGHT-SIDE UP VIEW (int. dimensions)

UPSIDE-DOWN VIEW (int. dimensions)

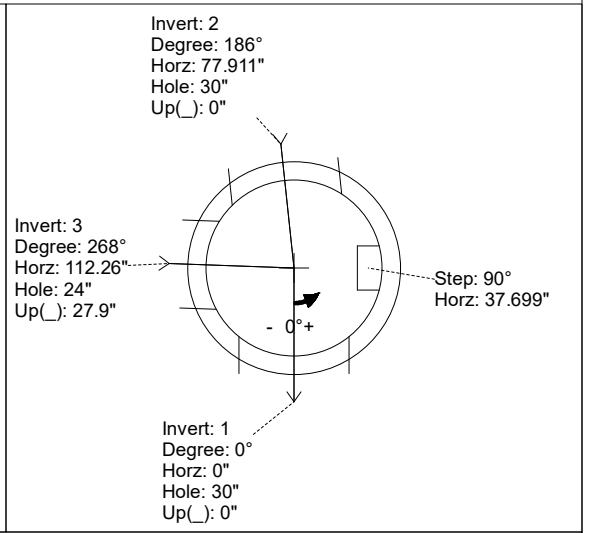
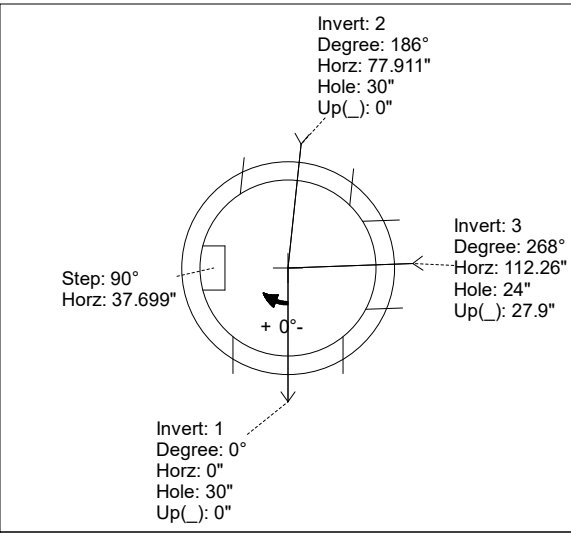
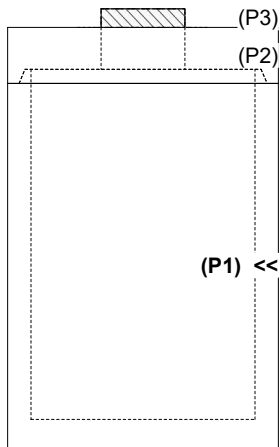

INSIDE WALL DIMENSIONS

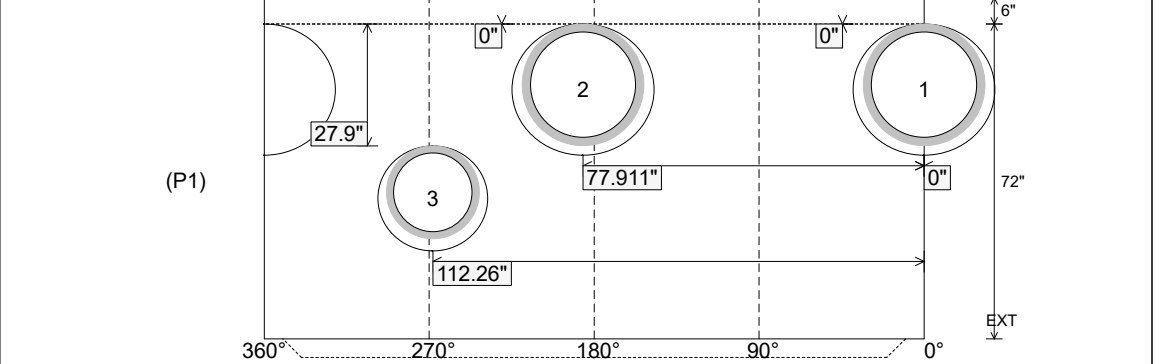

Coating (Int):  
 Coating (Ext):

Seam Up: Tongue  
 Seam Dn: n/a

Wall Thickness: 5"  
 Floor Height: 6"

Height (Int): 72"  
 Height (Ext): 78"

Weight (Net): 5531 lb  
 Volume (Net): 1.41cu.yd