

PLAN VIEW

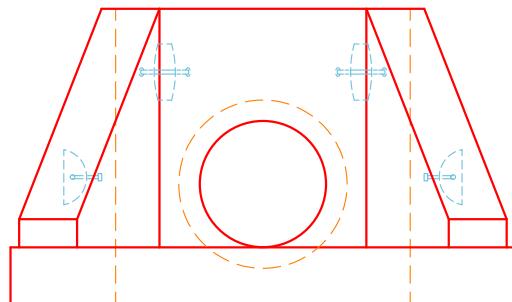

FRONT VIEW

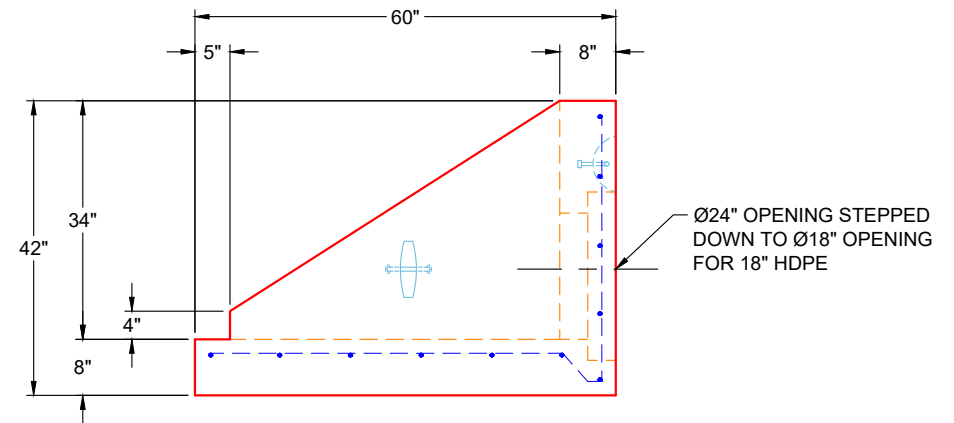

SIDE VIEW

GENERAL NOTES:

1. CONCRETE: 4,500 PSI AT 28 DAYS
2. REINFORCING: #4 BAR @ 12" C.C. E.W. (GRADE 60) - 2" MIN. REBAR CLEARANCE (TYP)
3. 3/4" CHAMBER ON ALL EXPOSED EDGES
4. WEIGHT: 4,300 LBS

PRODUCTION WORK ORDER

PRODUCT I.D.: HWSF18F

DESCRIPTION: 18" SLOPED & FLARED HW W/ FLAT BOTTOM



QUALITY CONTROL CHECKLIST

- ALL DIMENSIONS CORRECT.
- LIFTERS INSTALLED.
- OPENING CENTERED.
- REINFORCING CORRECT.
- SURFACE QUALITY ACCEPTABLE.
- EDGES CHAMFERED.
- ALL PATCHWORK ACCEPTABLE.

PRODUCT VIEW: RIGHT SIDE UP

CUSTOMER: INFINITY PIPELINE, INC.

PLANT: BEAVER DAM, KY

PROJECT: THE LAUREL ASSISTED LIVING FACILITY

WEIGHT: 4,300 LBS

STRUCTURE: LS-39

TOP SECTION JOINT: N / A

ORDER NO: 25-2649

BASE SECTION JOINT: N / A

PE: J.H. ROSS

DRAWING: K. CARDWELL

QC CHECK INITIALS:

DATE: 11/04/25

SCALE: NTS

PG. 1 OF 1