

Job Name: 25-2649 - The Laurel Assisted Living Facility
 Job Location: Bowling Green, KY
 Contractor: Infinity Pipeline, Inc.

Plant: Beaver Dam, KY

Tech: K. Cardwell

12/4/2025 2:57:42 PM

PC: E. Bradley



Structure ID: LS-31

P1 BX2424-08BAVF

BOX BASE 8inW, 8inF, Variable Ht F/n

- P3) 18" x 18" - CASTING HEIGHT - 4"
- P2) 24" x 24" - CB FLAT TOP 8"W w/18"x18" F/G F/F - 8"
- P1) 24" x 24" - BOX BASE 8inW, 8inF, Variable Ht F/n - 39"
- 1) CASTING - HOE 165A F/G
- 1) 24" x 24" - Conseal CS-102 1.00"
- 1) 18" x 18" - Conseal CS-102 1.00"
- 2) Hole - 16

- 0 lb
- 857 lb
- 4134 lb
- 138 lb
- 0 lb
- 0 lb
- 0 lb

Structure Total: 5129 lb

Structure Notes:

1. PER ASTM C-913 SPECS
2. CONCRETE: 4,500 PSI AT 28 DAYS
3. REINFORCEMENT: #5 BAR @ 12" C.C. E.W. (GRADE 60) - 2" MIN. REBAR CLEARANCE (TYP)
4. HOE 165-A FRAME & GRATE SUPPLIED BY ICAST

Rim: 551.67' Rim to Invert: 4.45' Slack: 2.4" Sump: 0" Step Position:

Position	Elev	Angle	Ext. (cw)	Pipe	Pipe OD	Connector	Hole	Horz Size	Up ()	Offset
Invert 1	547.22'	0°	20"	12" HDPE	14.5"	Hole 16	16"	16"	-1.25"	0"
Invert 2	547.22'	240°	15.381"	12" HDPE	14.5"	Hole 16	16"	18.475"	-1.25"	6"
Invert 3										
Invert 4										
Invert 5										
Invert 6										
Invert 7										
Invert 8										

RIGHT-SIDE UP VIEW (int. dimensions)

UPSIDE-DOWN VIEW (int. dimenions)

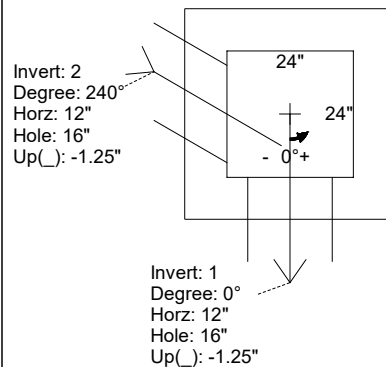
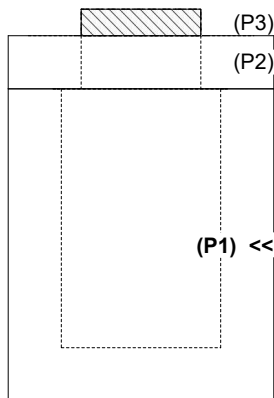

INSIDE WALL DIMENSIONS

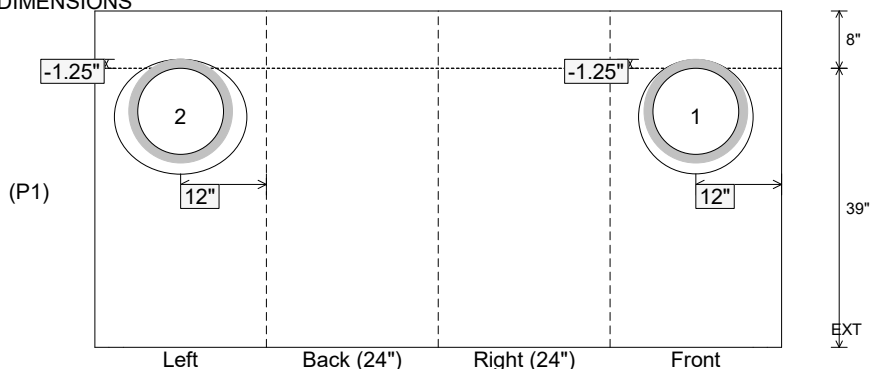

Coating (Int):
Coating (Ext):

Seam Up: Flat
Seam Dn: n/a

Wall Thickness: 8"
Floor Height: 8"

Height (Int): 39"
Height (Ext): 47"

Weight (Net): 4134 lb
Volume (Net): 1.06cu.yd