

Job Name: 25-2649 - The Laurel Assisted Living Facility  
 Job Location: Bowling Green, KY  
 Contractor: Infinity Pipeline, Inc.

Plant: Beaver Dam, KY  
 10/24/2025 7:29:11 AM

Tech: K. Cardwell  
 PC: E. Bradley



**Structure ID: LS-28**

**P2 MH048CN24**

**ECC CONE w/ 24" HOLE F/G**

- P3) 24" - CASTING HEIGHT - 6"
- P2) 48" - ECC CONE w/ 24" HOLE F/G - 24"
- P1) 48" - MH BASE Custom Ht T/n - 38"
- 1) CASTING - HOE MC-420 F/C Storm
- 1) 48" - Conseal CS-202 1.00"
- 1) Hole - 24
- 1) Hole - 16
- 1) Hole - 20
- 5) MH Step ML-10-TDS-NCR - 10"

0 lb  
 1550 lb  
 3567 lb  
 340 lb  
 0 lb  
 0 lb  
 0 lb  
 0 lb  
 0 lb  
 0 lb  
 -----  
 Structure Total: 5457 lb

- Structure Notes:
1. PER ASTM C-478 SPECS
  2. CONCRETE: 4,500 PSI AT 28 DAYS
  3. REINFORCEMENT: PER ASTM A615
  4. STEPS AT 250 DEGREES
  5. HOE MC-420 FRAME & COVER "STORM" SUPPLIED BY ICAST

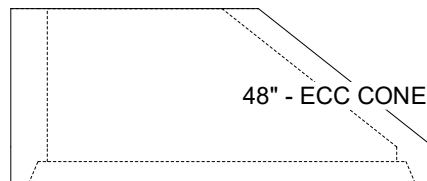
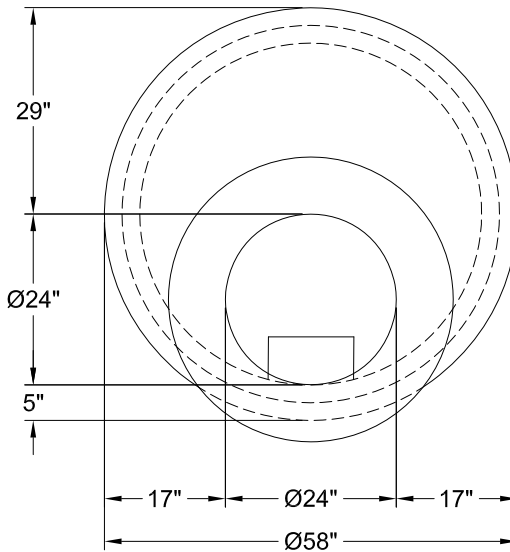

48" - ECC CONE w/ 24" HOLE F/G - 24" - (P2)

Coating (Int):  
 Coating (Ext):

Seam Up: Flat  
 Seam Dn: Groove

Wall Thickness: 5"

Height (Ext): 24"

Weight (Net): 1550 lb  
 Volume (Net): 0.33cu.yd