

Job Name: 25-2649 - The Laurel Assisted Living Facility
 Job Location: Bowling Green, KY
 Contractor: Infinity Pipeline, Inc.

Plant: Beaver Dam, KY
 10/24/2025 7:27:45 AM

Tech: K. Cardwell
 PC: E. Bradley



Structure ID: LS-28

P1 MH048BAVF

MH BASE Custom Ht T/n

- P3) 24" - CASTING HEIGHT - 6"
- P2) 48" - ECC CONE w/ 24" HOLE F/G - 24"
- P1) 48" - MH BASE Custom Ht T/n - 38"
- 1) CASTING - HOE MC-420 F/C Storm
- 1) 48" - Conseal CS-202 1.00"
- 1) Hole - 24
- 1) Hole - 16
- 1) Hole - 20
- 5) MH Step ML-10-TDS-NCR - 10"

0 lb
 1550 lb
 3567 lb
 340 lb
 0 lb
 0 lb
 0 lb
 0 lb
 0 lb
 0 lb
 Structure Total: 5457 lb

- Structure Notes:**
1. PER ASTM C-478 SPECS
 2. CONCRETE: 4,500 PSI AT 28 DAYS
 3. REINFORCEMENT: PER ASTM A615
 4. STEPS AT 250 DEGREES
 5. HOE MC-420 FRAME & COVER "STORM" SUPPLIED BY ICAST

Rim: 552.58' Rim to Invert: 5.84' Slack: 2.08" Sump: 0" Step Position: 250

Position	Elev	Angle	Ext. (cw)	Pipe	Pipe OD	Connector	Hole	Horz Size	Up ()	Offset
Invert 1	546.74'	0°	0"	18" HDPE	21.2"	Hole 24	24"	25.133"	-1.6"	0"
Invert 2	547.11'	83°	42.01"	12" HDPE	14.5"	Hole 16	16"	16.312"	3.19"	0"
Invert 3	546.74'	138°	69.848"	15" HDPE	17.6"	Hole 20	20"	20.629"	-1.3"	0"
Invert 4										
Invert 5										
Invert 6										
Invert 7										
Invert 8										

RIGHT-SIDE UP VIEW (int. dimensions)

UPSIDE-DOWN VIEW (int. dimensions)

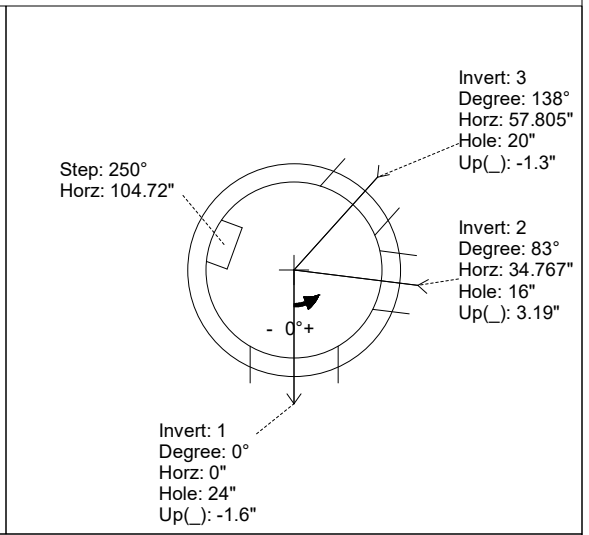
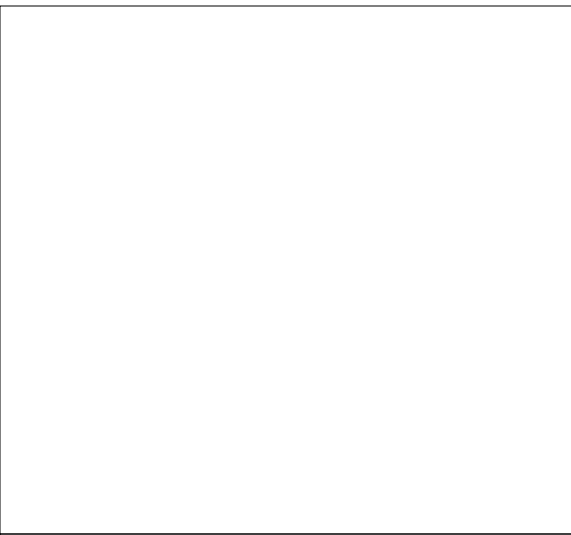
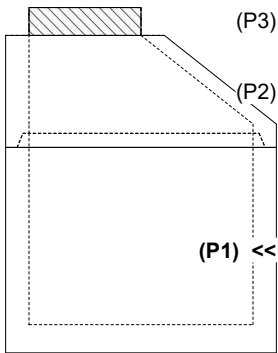

INSIDE WALL DIMENSIONS

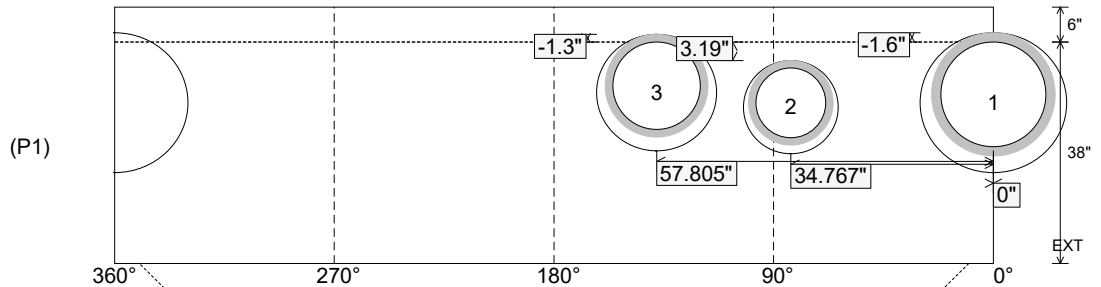

Coating (Int):
 Coating (Ext):

Seam Up: Tongue
 Seam Dn: n/a

Wall Thickness: 5"
 Floor Height: 6"

Height (Int): 38"
 Height (Ext): 44"

Weight (Net): 3567 lb
 Volume (Net): 0.91cu.yd