

Job Name: 25-2649 - The Laurel Assisted Living Facility
 Job Location: Bowling Green, KY
 Contractor: Infinity Pipeline, Inc.

Plant: Beaver Dam, KY
 10/24/2025 7:29:10 AM

Tech: K. Cardwell
 PC: E. Bradley



Structure ID: LS-15

P2 MH048LD12-18X18

MH FLAT TOP w/18"x18" Hole F/G

- P4) 18" x 18" - CASTING HEIGHT - 4"
- P3) 18" x 18" - GRADE RING F/F - 3"
- P2) 48" - MH FLAT TOP w/18"x18" Hole F/G - 12"
- P1) 48" - MH BASE T/n - 42"
- 1) CASTING - HOE 165A F/G
- 1) 48" - Conseal CS-102 1.00"
- 2) 18" x 18" - Conseal CS-102 1.00"
- 1) Hole - 20
- 1) Hole - 16
- 1) Hole - 14
- 4) MH Step ML-10-TDS-NCR - 10"

0 lb
 209 lb
 2334 lb
 3978 lb
 138 lb
 0 lb
 0 lb
 0 lb
 0 lb
 0 lb
 0 lb

Structure Total: 6660 lb

- Structure Notes:
1. PER ASTM C-478 SPECS
 2. CONCRETE: 4,500 PSI AT 28 DAYS
 3. REINFORCEMENT: #4 BAR @ 10" C.C. E.W. (GRADE 60) - 2" MIN. REBAR CLEARANCE (TYP)
 4. STEPS AT 60 DEGREES
 5. HOE 165-A FRAME & GRATE SUPPLIED BY ICAST
 6. LIFTERS: 4 EA. WRA016 CONAC WIRE ROPE ANCHORS FOR PLANT & FIELD HANDLING

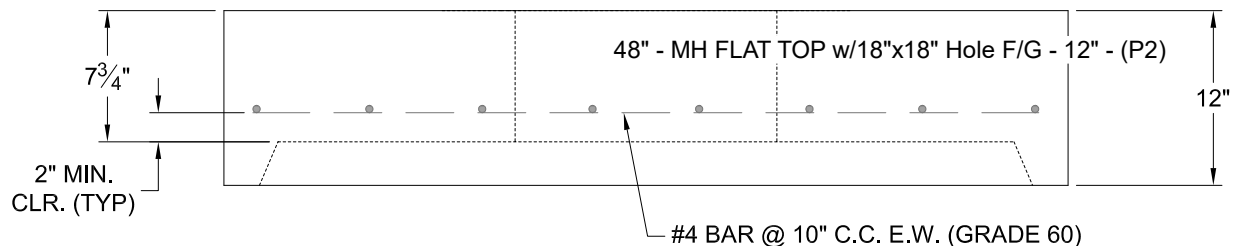
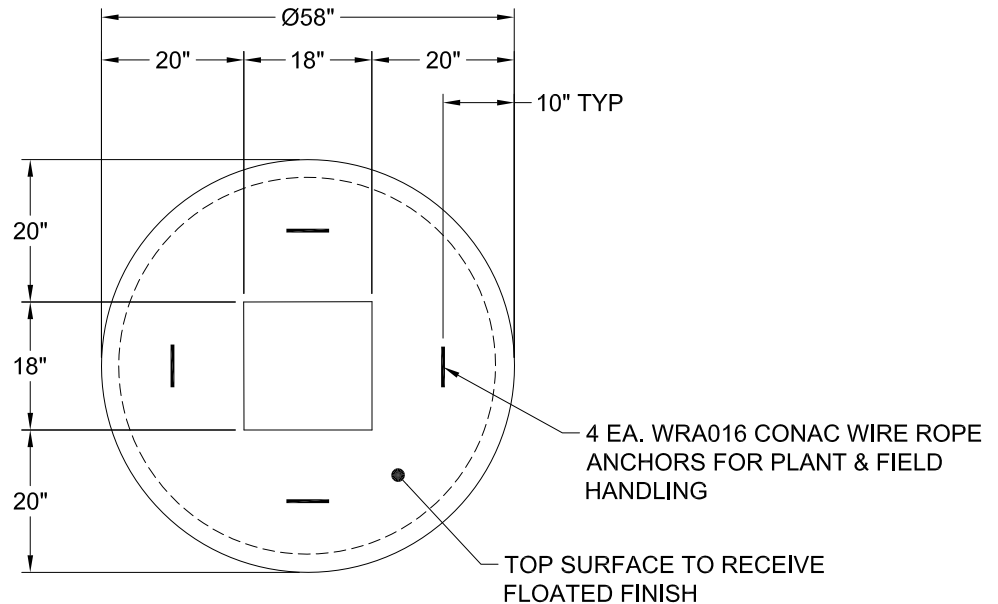

Coating (Int): Coating (Ext):	Seam Up: Flat Seam Dn: Groove	Wall Thickness: 5"	Height (Ext): 12"	Weight (Net): 2334 lb Volume (Net): 0.6cu.yd
----------------------------------	----------------------------------	--------------------	-------------------	---