

Job Name: 25-2649 - The Laurel Assisted Living Facility
 Job Location: Bowling Green, KY
 Contractor: Infinity Pipeline, Inc.

Plant: Beaver Dam, KY

Tech: K. Cardwell

10/24/2025 7:27:41 AM

PC: E. Bradley



Structure ID: LS-15

P1 MH048BA42

MH BASE T/n

- P4) 18" x 18" - CASTING HEIGHT - 4"
- P3) 18" x 18" - GRADE RING F/F - 3"
- P2) 48" - MH FLAT TOP w/18"x18" Hole F/G - 12"
- P1) 48" - MH BASE T/n - 42"
- 1) CASTING - HOE 165A F/G
- 1) 48" - Conseal CS-102 1.00"
- 2) 18" x 18" - Conseal CS-102 1.00"
- 1) Hole - 20
- 1) Hole - 16
- 1) Hole - 14
- 4) MH Step ML-10-TDS-NCR - 10"

- Structure Notes:**
1. PER ASTM C-478 SPECS
 2. CONCRETE: 4,500 PSI AT 28 DAYS
 3. REINFORCEMENT: PER ASTM A615
 4. STEPS AT 60 DEGREES
 5. HOE 165-A FRAME & GRATE SUPPLIED BY ICAST

0 lb
 209 lb
 2334 lb
 3978 lb
 138 lb
 0 lb
 0 lb
 0 lb
 0 lb
 0 lb
 0 lb

Structure Total: 6660 lb

Rim: 551.85' Rim to Invert: 5.24' Slack: 1.88" Sump: 0" Step Position: 60

Position	Elev	Angle	Ext. (cw)	Pipe	Pipe OD	Connector	Hole	Horz Size	Up ()	Offset
Invert 1	546.61'	0°	0"	15" HDPE	17.6"	Hole 20	20"	20.629"	-1.3"	0"
Invert 2	546.78'	135°	68.33"	12" HDPE	14.5"	Hole 16	16"	16.312"	0.79"	0"
Invert 3	548.56'	226°	114.389"	10" HDPE	11.4"	Hole 14	14"	14.207"	22.7"	0"
Invert 4										
Invert 5										
Invert 6										
Invert 7										
Invert 8										

RIGHT-SIDE UP VIEW (int. dimensions)

UPSIDE-DOWN VIEW (int. dimensions)

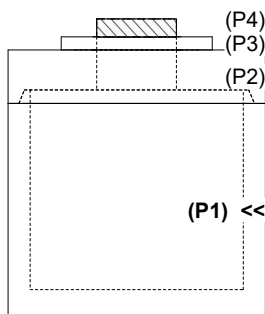
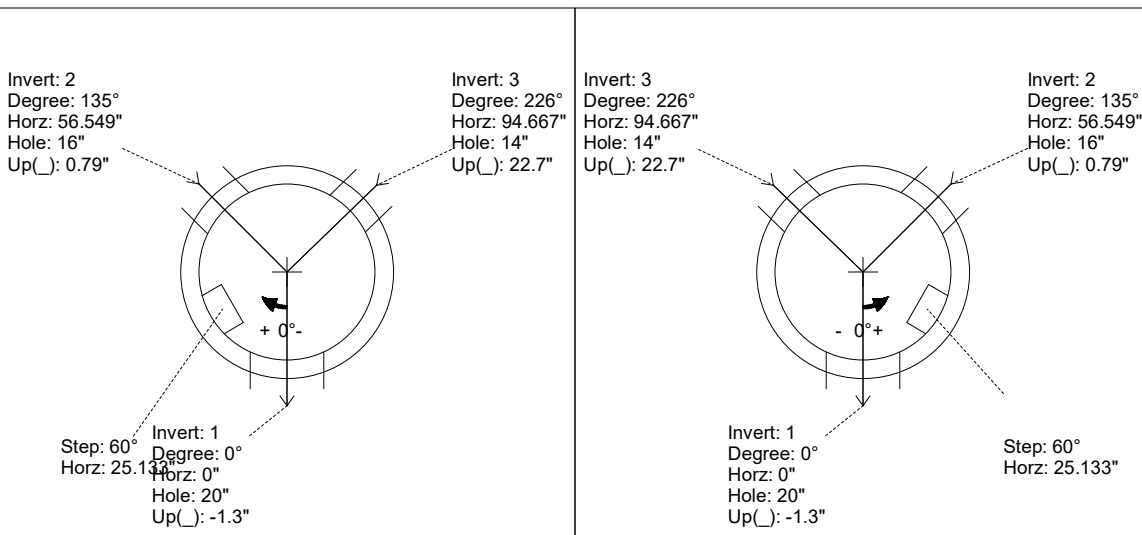

INSIDE WALL DIMENSIONS

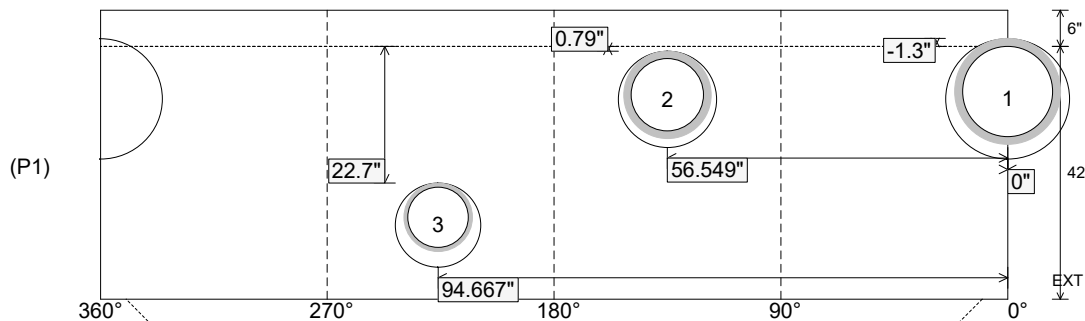

Coating (Int):
 Coating (Ext):

Seam Up: Tongue
 Seam Dn: n/a

Wall Thickness: 5"
 Floor Height: 6"

Height (Int): 42"
 Height (Ext): 48"

Weight (Net): 3978 lb
 Volume (Net): 1.02cu.yd