

PLAN VIEW

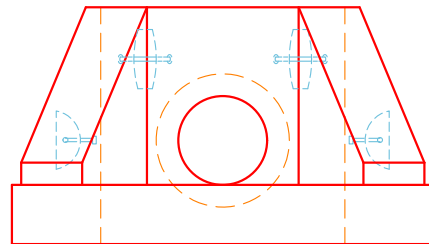

FRONT VIEW

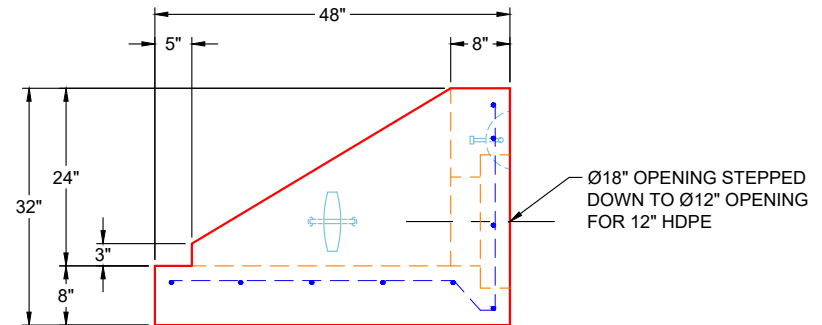

SIDE VIEW

GENERAL NOTES:

1. CONCRETE: 4,500 PSI AT 28 DAYS
2. REINFORCING: #4 BAR @ 12" C.C. E.W. (GRADE 60)
3. PIPE AND LIFTING ANCHOR POCKETS TO BE GROUTED WITH NON-SHRINK GROUT
4. 3/4" CHAMBER ON ALL EXPOSED EDGES
5. WEIGHT: 2,545 LBS

REVISION INFORMATION

REV.	DATE:	NO REVISIONS TO DATE



SUBMITTAL DRAWING: 12" SF HW FLAT BOTTOM		
CUSTOMER: INFINITY PIPELINE, INC.		
PROJECT: THE LAUREL ASSISTED LIVING FACILITY		
STRUCTURE: LS-1		
QUOTE/SALES ORDER NO: 25-2649		
CHECKED BY: B. SMITH	DRAWN BY: K. CARDWELL	
DATE: 11/04/25	SCALE: NTS	PG. 1 OF 1