

Job Name: 25-2644 Limestone Edge Apartments
 Job Location: Bedford, IN
 Contractor: S&J Excavation

Plant: Beaver Dam

10/13/2025 9:12:15 AM

Tech: J. Coppage

PC: J. Jarvis



Structure ID: STR-36

P1 BX2424-08BAVF

BOX BASE 8inW, 8inF, Variable Ht

- P2) 24" x 24" - CASTING HEIGHT - 1"
- P1) 24" x 24" - BOX BASE 8inW, 8inF, Variable Ht - 29"
- 1) CASTING - EJ 6500 GRT
- 1) 24" x 24" - Conseal CS-102 1.00"
- 1) Hole - 18
- 1) Hole - 10

Structure Total: 3592 lb

Structure Notes:

1. EJ-6500 GRATE PROVIDED BY ICAST.
 2. INDOT INLET TYPE A / ASTM C913 SPEC'S.
 3. CONCRETE = 4,000 PSI AT 28 DAYS.
 4. REINFORCING PER ASTM A615 (GRADE 60).
- WALLS (As .31) #5 BARS AT 12" C.C.E.W.
 - FLOOR (As .31) #5 BARS AT 12" C.C.E.W.

Rim: 642' Rim to Invert: 2.5' Slack: 0" Sump: 0" Step Position:

Position	Elev	Angle	Ext. (cw)	Pipe	Pipe OD	Connector	Hole	Horz Size	Up ()	Offset
Invert 1	639.5'	180°	20"	12" HDPE	14.5"	Hole 18	18"	18"	-1.25"	0"
Invert 2	639.75'	90°	20"	6" HDPE	6.9"	Hole 10	10"	10"	2.55"	0"
Invert 3										
Invert 4										
Invert 5										
Invert 6										
Invert 7										
Invert 8										

RIGHT-SIDE UP VIEW (int. dimensions)

UPSIDE-DOWN VIEW (int. dimensions)

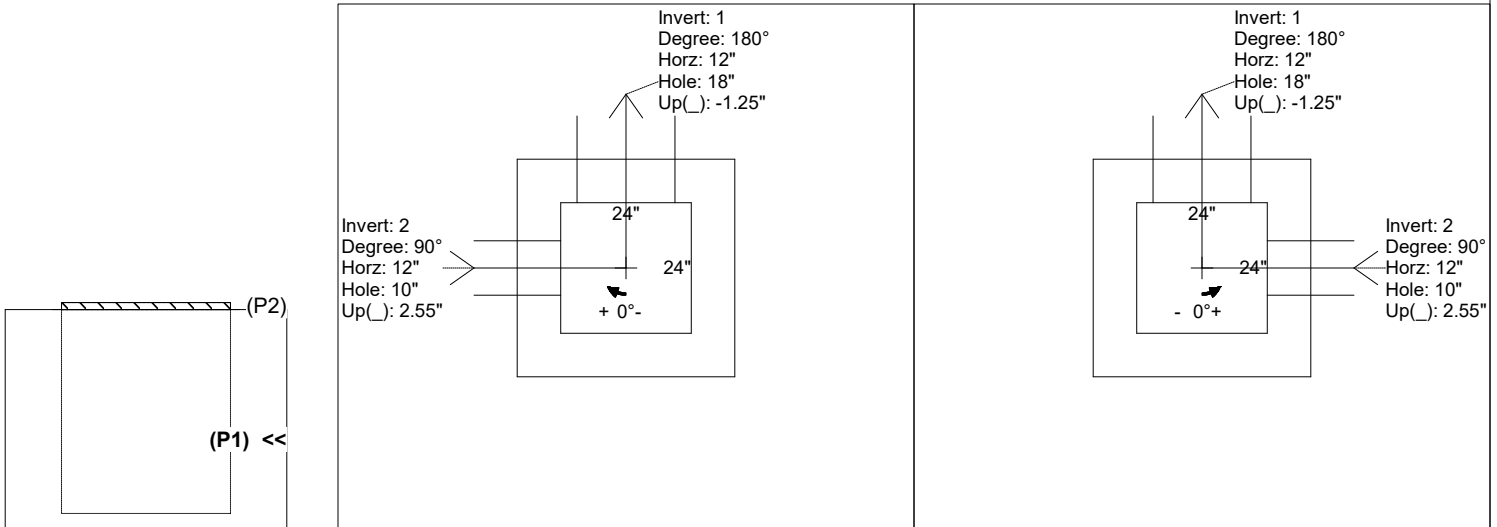

INSIDE WALL DIMENSIONS

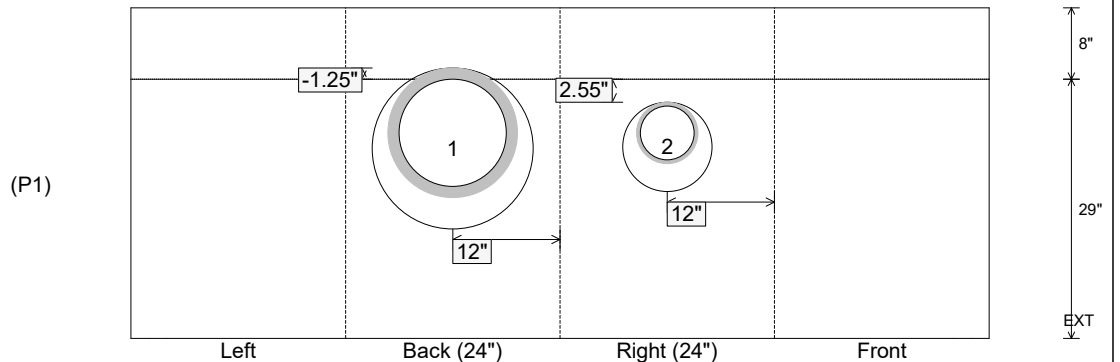

Coating (Int):
 Coating (Ext):

Seam Up: Flat
 Seam Dn: n/a

Wall Thickness: 8"
 Floor Height: 8"

Height (Int): 29"
 Height (Ext): 37"

Weight (Net): 3342 lb
 Volume (Net): 0.85cu.yd