

TOP VIEW

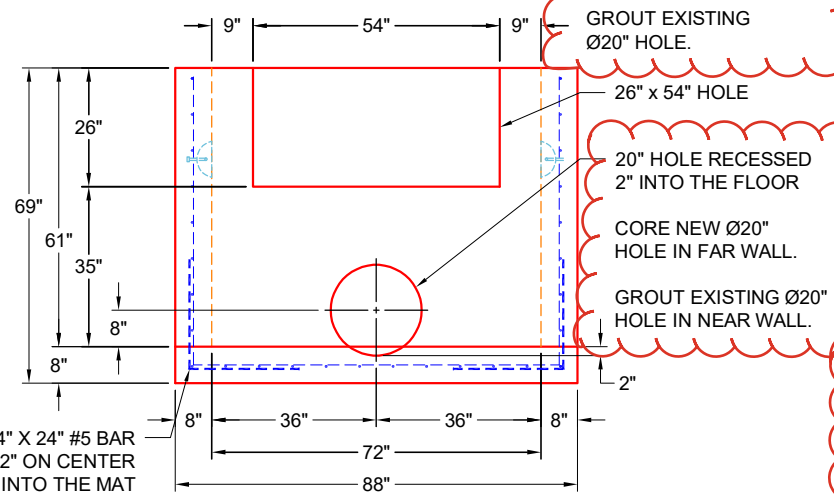

FRONT VIEW

4 EA. 6CA18 CONAC
A-ANCHORS AS SHOWN

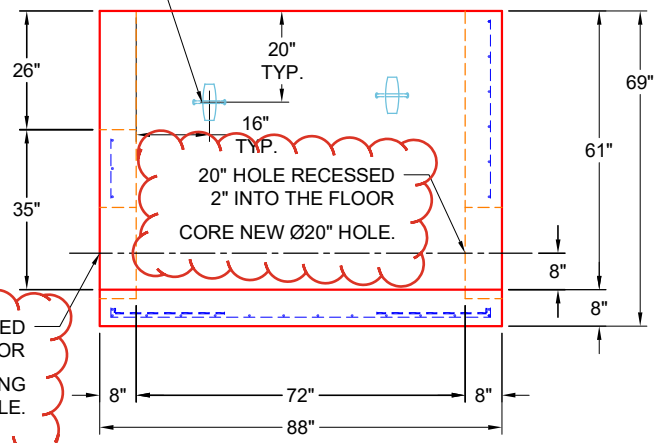

RIGHT SIDE

GENERAL NOTES:

1. MANUFACTURED TO ASTM C-913 (LATEST REVISION).
2. CONCRETE: 5,000 PSI AT 28 DAYS.
3. REINFORCING: #4 BAR @ 8" O.C.E.W (GRADE 60)
4. WEIGHT: 17,150 LBS

PRODUCTION WORK ORDER

PRODUCT I.D.: BX072072-08BA-VH

DESCRIPTION: 72" X 72" X 61" VAULT



QUALITY CONTROL CHECKLIST

- ALL DIMENSIONS CORRECT.
- LIFTERS INSTALLED.
- OPENING CENTERED.
- REINFORCING CORRECT.
- SURFACE QUALITY ACCEPTABLE.
- EDGES CHAMFERED.
- ALL PATCHWORK ACCEPTABLE.

PRODUCT VIEW: UPSIDE DOWN

CUSTOMER: BOWEN ENGINEERING

PLANT: BEAVER DAM, KY.

PROJECT: KUB WTP MANHOLE

WEIGHT: 17,150 LBS.

STRUCTURE: VAULT 2 BASE REWORK

TOP JOINT: FLAT

ORDER NO: 25-2636

BOTTOM JOINT: N/A

PE: J.H. ROSS

DRAWING: J. COPPAGE

QC CHECK INITIALS:

DATE: 11/4/26

SCALE: NTS

PG. 1 of 1