

Job Name: 25-2636 KUB WTP Manhole
 Job Location: Knoxville, TN
 Contractor: Bowen Engineering Corporation

Plant: Beaver Dam, KY
 4/3/2026 7:58:04 AM

Tech: Evan Niles
 PC: Jay Jarvis



Structure ID: VAULT 1 TOP SLAB REWORK

P1 BX072072-08TS-S

CB FLAT TOP 8"W SOLID

P1) 72" x 72" - CB FLAT TOP 8"W SOLID - 8"
 1) CASTING - HOE 280T Frame/Solid Cover

5199 lb
 257 lb

 Structure Total: 5456 lb

Structure Notes:

1. PER ASTM C913 SPECIFICATIONS. (LATEST REVISION)
2. CONCRETE = 5,000 PSI AT 28 DAYS.
3. REINFORCING: #4 BAR @ 8" O.C. E.W. (GRADE 60)

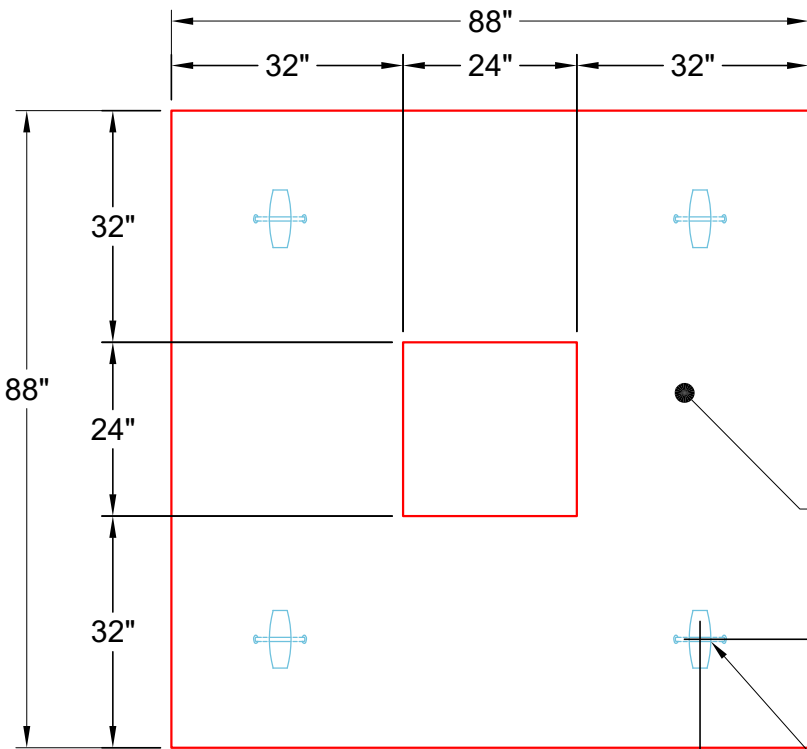

GENERAL NOTES:

1. MANUFACTURED TO ASTM C-913 (LATEST REVISION).
2. CONCRETE: 5,000 PSI AT 28 DAYS.
3. REINFORCING: #4 BAR @ 8" O.C.E.W (GRADE 60)
4. JR HOE HOE-280T W/ SOLID COVER PROVIDED BY ICAST.

LIGHT BROOM FINISH

15" TYP.

15" TYP.

4 EA. 5CA14 CONAC A-ANCHORS REQUIRED.

TOP VIEW

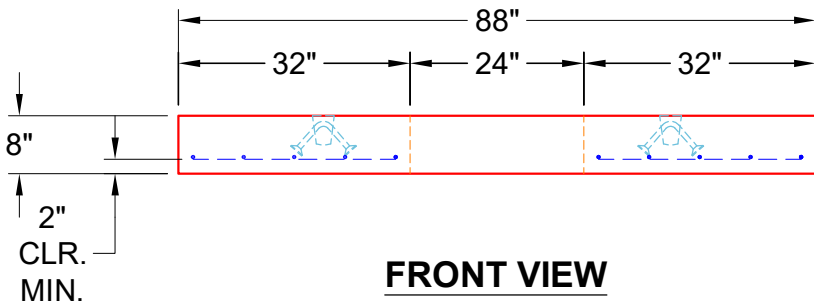

FRONT VIEW

Coating (Int):
 Coating (Ext):

Seam Up: Flat
 Seam Dn: Flat

Wall Thickness: 8"

Height (Ext): 8"

Weight (Net): 5199 lb
 Volume (Net): 1.33cu.yd