

TOP VIEW

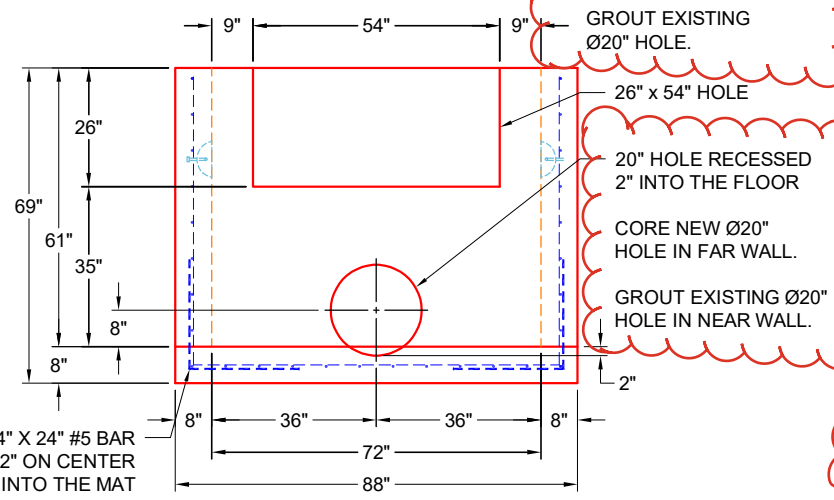

FRONT VIEW

4 EA. 6CA18 CONAC
A-ANCHORS AS SHOWN

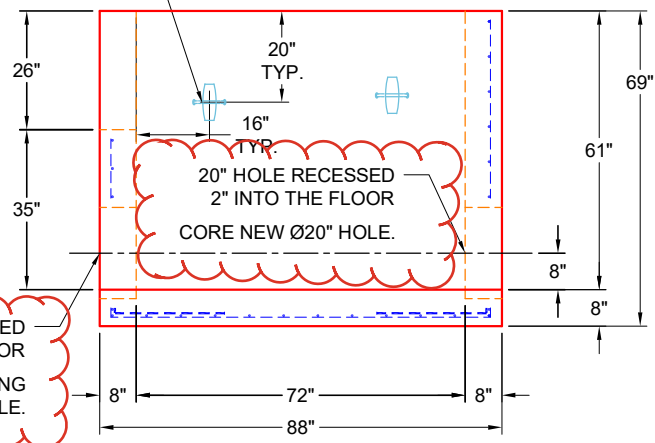

RIGHT SIDE

GENERAL NOTES:

1. MANUFACTURED TO ASTM C-913 (LATEST REVISION).
2. CONCRETE: 5,000 PSI AT 28 DAYS.
3. REINFORCING: #4 BAR @ 8" O.C.E.W (GRADE 60)
4. WEIGHT: 17,150 LBS

		QUALITY CONTROL CHECKLIST <input type="checkbox"/> ALL DIMENSIONS CORRECT. <input type="checkbox"/> LIFTERS INSTALLED. <input type="checkbox"/> OPENING CENTERED. <input type="checkbox"/> REINFORCING CORRECT. <input type="checkbox"/> SURFACE QUALITY ACCEPTABLE. <input type="checkbox"/> EDGES CHAMFERED. <input type="checkbox"/> ALL PATCHWORK ACCEPTABLE.	PRODUCT I.D.: BX072072-08BA-VH PRODUCT VIEW: UPSIDE DOWN PLANT: BEAVER DAM, KY. WEIGHT: 17,150 LBS. TOP JOINT: FLAT BOTTOM JOINT: N/A QC CHECK INITIALS:	DESCRIPTION: 72" X 72" X 61" VAULT CUSTOMER: BOWEN ENGINEERING PROJECT: KUB WTP MANHOLE STRUCTURE: VAULT 1 BASE REWORK ORDER NO: 25-2636 PE: J.H. ROSS DRAWING: J. COPPAGE DATE: 11/4/26 SCALE: NTS PG. 1 of 1
---	--	---	---	--