

Job Name: 25-2631 The Maxwell PH 2  
 Job Location: Lexington, KY  
 Contractor: Woodall Construction Co., Inc.

Plant: Beaver Dam

Tech: C.Russ

11/7/2025 12:46:20 PM

PC: T. Ryan



**Structure ID: SSMH-1**

**P1 MH048BA24**

**MH BASE Custom Ht**

- P3) 24" - CASTING HEIGHT - 7"
- P2) 48" - MH FLAT TOP w/ 24" ECC Hole - 12"
- P1) 48" - MH BASE Custom Ht - 24"

- 1) JOINT WRAP - 0.065"x6"x50' CONSEAL CS212
- 1) JOINT WRAP PRIMER - CONSEAL CS-75 (1 gal.)
- 1) 48" - MH INVERT CHANNEL - FULL HEIGHT
- 1) 48" - DBL 1"x14.5' Butyl (2x)
- 3) PSX - 12-08 NYLO
- 1) MH Step ML-10-TDS-NCR - 10"

- Structure Notes:**
1. CASTING PROVIDED BY OTHERS
  2. PER ASTM C478 SPECIFICATIONS.
  3. CONCRETE = 4,000 PSI AT 28 DAYS.
  4. REINFORCING PER ASTM A615 (GRADE 60).
    - CONE (As .12)
    - RISER/WALLS (As .12)
    - FLOOR (As .31) #5 BARS AT 12" C.C.E.W.

Structure Total: 5888 lb

Rim: 986.46' Rim to Invert: 3.44' Slack: 0.28" Sump: 2" Step Position: 0°

Position	Elev	Angle	Ext. (cw)	Pipe	Pipe OD	Connector	Hole	Horz Size	Up ( )	Offset
Invert 1	983.02'	0°	0"	8" PVC SDR35	8.5"	PSX 12-08 NYLO	12"	12.129"	0"	0"
Invert 2	983.07'	180°	91.106"	8" PVC SDR35	8.5"	PSX 12-08 NYLO	12"	12.129"	0.6"	0"
Invert 3	983.17'	270°	136.659"	8" PVC SDR35	8.5"	PSX 12-08 NYLO	12"	12.129"	1.8"	0"
Invert 4										
Invert 5										
Invert 6										
Invert 7										
Invert 8										

RIGHT-SIDE UP VIEW (int. dimensions)

UPSIDE-DOWN VIEW (int. dimensions)

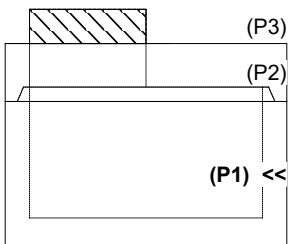
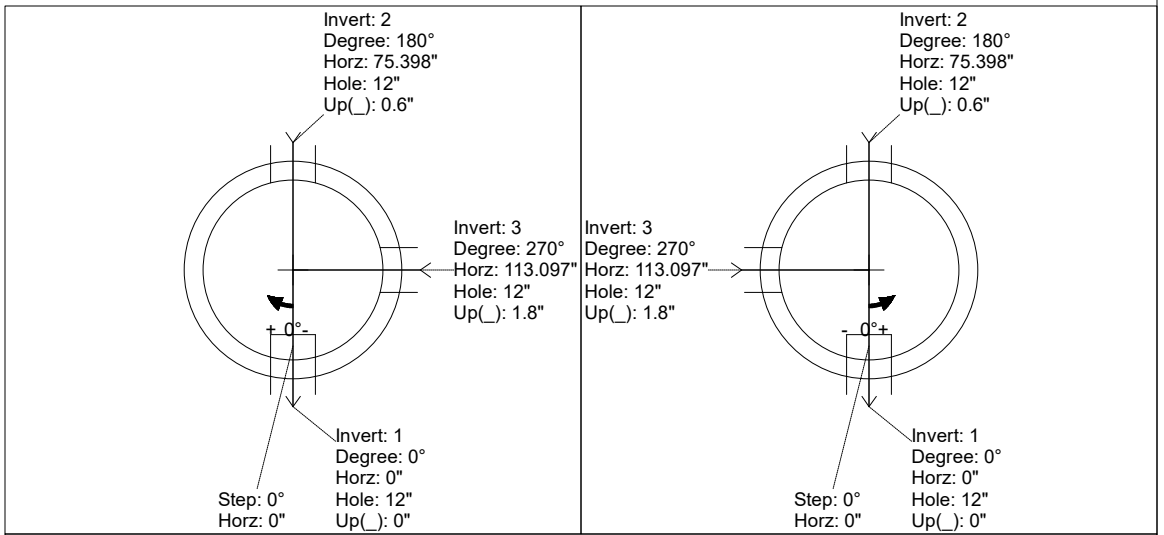

INSIDE WALL DIMENSIONS

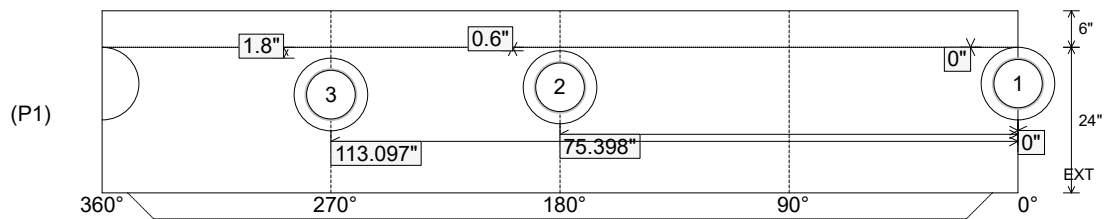

Coating (Int):  
 Coating (Ext):

Seam Up: Tongue  
 Seam Dn: n/a

Wall Thickness: 5"  
 Floor Height: 6"

Height (Int): 24"  
 Height (Ext): 30"

Weight (Net): 2863 lb  
 Volume (Net): 0.73cu.yd

Job Name: 25-2631 The Maxwell PH 2  
 Job Location: Lexington, KY  
 Contractor: Woodall Construction Co., Inc.

Plant: Beaver Dam

Tech: C.Russ

11/7/2025 12:46:20 PM

PC: T. Ryan



**Structure ID: SSMH-1**

**P1 MH048BA24**

**MH BASE Custom Ht**

- P3) 24" - CASTING HEIGHT - 7"
- P2) 48" - MH FLAT TOP w/ 24" ECC Hole - 12"
- P1) 48" - MH BASE Custom Ht - 24"
- 1) JOINT WRAP - 0.065"x6"x50' CONSEAL CS212
- 1) JOINT WRAP PRIMER - CONSEAL CS-75 (1 gal.)
- 1) 48" - MH INVERT CHANNEL - FULL HEIGHT
- 1) 48" - DBL 1"x14.5' Butyl (2x)
- 3) PSX - 12-08 NYLO
- 1) MH Step ML-10-TDS-NCR - 10"

- Structure Notes:**
1. CASTING PROVIDED BY OTHERS
  2. PER ASTM C478 SPECIFICATIONS.
  3. CONCRETE = 4,000 PSI AT 28 DAYS.
  4. REINFORCING PER ASTM A615 (GRADE 60).
    - CONE (As .12)
    - RISER/WALLS (As .12)
    - FLOOR (As .31) #5 BARS AT 12" C.C.E.W.

Structure Total: 5888 lb

**INVERT CHANNEL DRAWING  
 FULL HEIGHT INVERT**

Rim: 986.46' Rim to Invert: 3.44' Slack: 0.28" Sump: 2" Step Position: 0°

Position	Elev	Angle	Ext. (cw)	Pipe	Pipe OD	Connector	Hole	Horz Size	Up ( )	Offset
Invert 1	983.02'	0°	0"	8" PVC SDR35	8.5"	PSX 12-08 NYLO	12"	12.129"	0"	0"
Invert 2	983.07'	180°	91.106"	8" PVC SDR35	8.5"	PSX 12-08 NYLO	12"	12.129"	0.6"	0"
Invert 3	983.17'	270°	136.659"	8" PVC SDR35	8.5"	PSX 12-08 NYLO	12"	12.129"	1.8"	0"
Invert 4										
Invert 5										
Invert 6										
Invert 7										
Invert 8										

RIGHT-SIDE UP VIEW (int. dimensions)

UPSIDE-DOWN VIEW (int. dimensions)

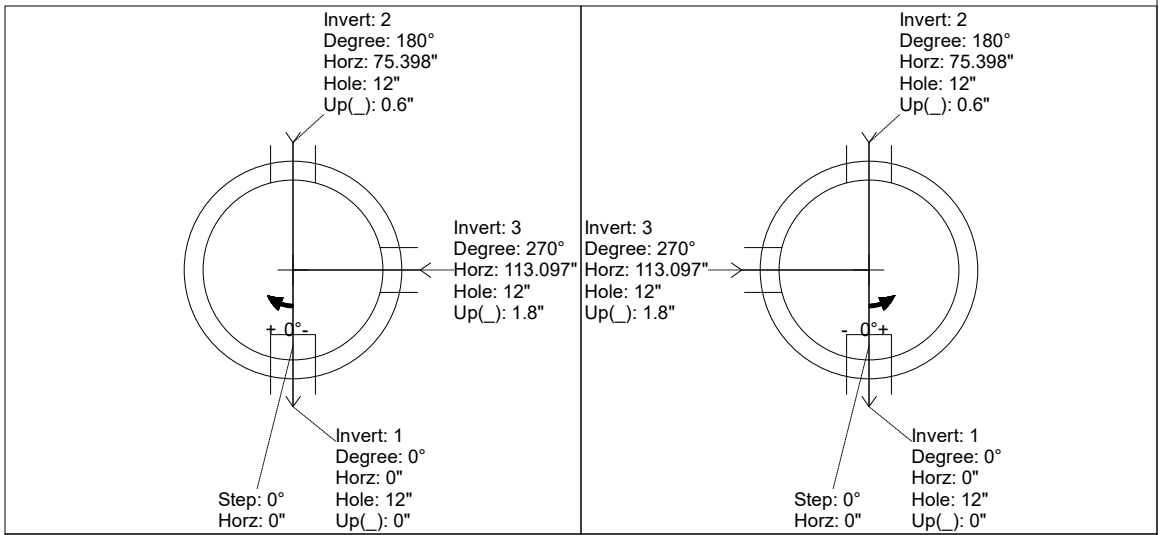
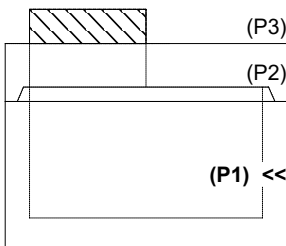

INSIDE WALL DIMENSIONS

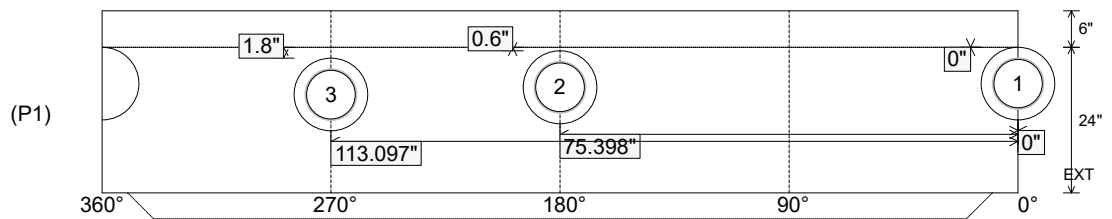

Coating (Int):  
 Coating (Ext):

Seam Up: Tongue  
 Seam Dn: n/a

Wall Thickness: 5"  
 Floor Height: 6"

Height (Int): 24"  
 Height (Ext): 30"

Weight (Net): 2863 lb  
 Volume (Net): 0.73cu.yd