

Job Name: 25-2621 Night Hawk Place Lot 2G Storm
 Job Location: Radcliff, KY
 Contractor: City of Radcliff

Plant: Beaver Dam

Tech: C.Russ

11/13/2025 1:45:40 PM

PC: J.Jarvis



Structure ID: JB G

P3 MH060LD13

MH FLAT TOP w/ 24" ECC Hole

- P4) 24" - CASTING HEIGHT - 4"
- P3) 60" - MH FLAT TOP w/ 24" ECC Hole - 13"
- P2) 60" - MH RISER Custom Ht - 35"
- P1) 60" - MH BASE - 48"
- 2) 60" - SGL 1"x14.5' Butyl (2x)
- 2) Hole - 38
- 4) MH Step ML-10-TDS-NCR - 10"

- 0 lb Structure Notes:
1. PER ASTM C478 SPECIFICATIONS.
 2. CONCRETE = 4,000 PSI AT 28 DAYS.
 3. HOE KY-206 BY ICAST
 4. REINFORCING PER ASTM A615 (GRADE 60).
 - TOP SLAB (As .62) #5 BARS AT 6" C.C.E.W..
 - RISER/WALLS (As .18)
 - FLOOR (As .37) #5 BARS AT 10" C.C.E.W.

Structure Total: 13047 lb

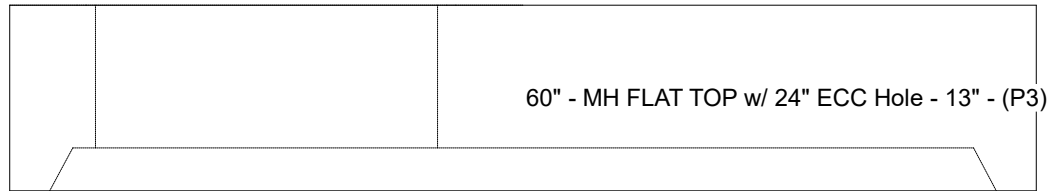
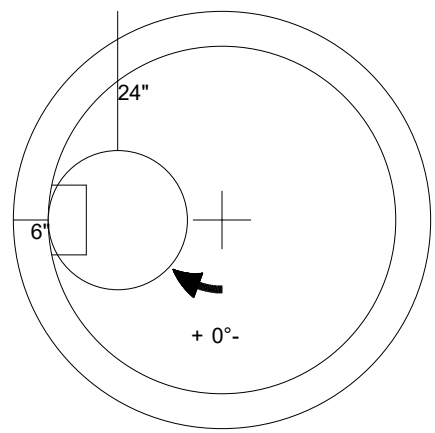

Coating (Int):
 Coating (Ext):

Seam Up: Flat
 Seam Dn: Groove

Wall Thickness: 6"

Height (Ext): 13"

Weight (Net): 2869 lb
 Volume (Net): 0.73cu.yd