

Job Name: 25-2621 Night Hawk Place Lot 2G Storm
 Job Location: Radcliff, KY
 Contractor: City of Radcliff

Plant: Beaver Dam

Tech: C.Russ

11/13/2025 1:45:41 PM

PC: J.Jarvis



Structure ID: DBI L

P2 MH048LD07ECC

MH FLAT LID w/24in ECC Hole

- P3) 24" - CASTING HEIGHT - 4"
- P2) 48" - MH FLAT LID w/24in ECC Hole - 7"
- P1) 48" - MH BASE Custom Ht - 35"
- 1) 48" - SGL 1"x14.5' Butyl (2x)
- 1) Hole - 30
- 1) Hole - 20
- 1) Hole - 24
- 3) MH Step ML-10-TDS-NCR - 10"

- 0 lb Structure Notes:
1. PER ASTM C478 SPECIFICATIONS.
 2. CONCRETE = 4,000 PSI AT 28 DAYS.
 3. HOE MCB-260 BH
 4. REINFORCING PER ASTM A615 (GRADE 60).
- TOP SLAB (As .62) #5 BARS AT 6" C.C.E.W..
 - RISER/WALLS (As .12)
 - FLOOR (As .31) #5 BARS AT 12" C.C.E.W.

Structure Total: 4413 lb

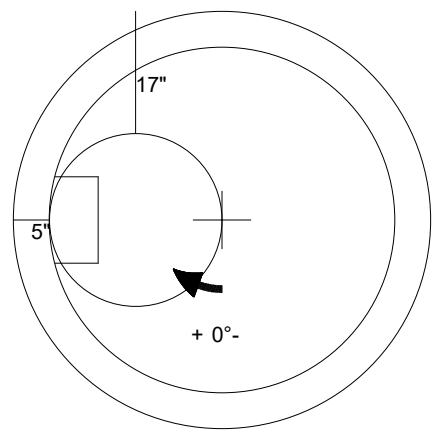

	48" - MH FLAT LID w/24in ECC Hole - 7" - (P2)
--	---

Coating (Int):
 Coating (Ext):

Seam Up: Flat
 Seam Dn: Flat

Wall Thickness: 5"

Height (Ext): 7"

Weight (Net): 1286 lb
 Volume (Net): 0.33cu.yd