

Job Name: 25-2601 Spring Creek Parkway Phase 2 (Storm)  
 Job Location: Clarksville, TN  
 Contractor: Byard Construction, LLC

Plant: Beaver Dam  
 2/24/2026 10:39:25 AM

Tech: S. Felletter  
 PC: A. Chambers



**Structure ID: CB-45**

**P2 MH096RS48S**

**MH RISER SPECIAL T/G**

- P6) 28" x 34" - CASTING HEIGHT - 7"
- P5) 96" - MH FLAT TOP - TDOT NO 12 (28"x34" Hole) F/F - 10"
- P4) 96" - MH RISER Custom Ht F/G - 76"
- P3) 96" - MH RISER SPECIAL T/G - 48"
- P2) 96" - MH RISER SPECIAL T/G - 48"
- P1) 96" - MH MONOBASE 8F, Custom Ht T/n - 32"
- 4) 96" - Conseal CS-102 1.00"
- 1) 28" x 34" - Conseal CS-102 1.00"
- 2) Hole - 60
- 1) Hole - 39
- 1) Hole - 6

0 lb  
 7767 lb  
 17987 lb  
 11958 lb  
 9778 lb  
 12448 lb  
 0 lb  
 0 lb  
 0 lb  
 0 lb  
 0 lb  
 -----  
 Structure Total: 59938 lb

- Structure Notes:**
1. PER TDOT D-CB-12RC / ASTM C478 SPEC'S.
  2. CONCRETE = 4,000 PSI AT 28 DAYS.
  3. NO INVERT CHANNEL.
  4. CASTING BY OTHERS (TDOT TY. 12 - JBS 3123 MOD F/G/H).

REINFORCING PER ASTM A615 (GRADE 60).  
 \*\* PER TDOT STD DRAWING D-CB-12RC \*\*  
 - TOP SLAB - DBL MAT #5 BARS.  
 - RISER (As .18)  
 - FLOOR (As .62) #5 BARS AT 6" C.C.E.W.

Rim: 499.64' Rim to Invert: 18.27' Slack: 0.24" Sump: 2" Step Position:

Position	Elev	Angle	Ext. (cw)	Pipe	Pipe OD	Connector	Hole	Horz Size	Up ( )	Offset
Invert 1	481.37'	0°	0"	54" CMP	55"	Hole 60	60"	64.813"	-35.5"	0"
Invert 2										
Invert 3	481.66'	222°	220.854"	48" RCP B WALL	58"	Hole 60	60"	64.813"	-36.52"	0"
Invert 4										
Invert 5										
Invert 6										
Invert 7										
Invert 8										

**RIGHT-SIDE UP VIEW (int. dimensions)**

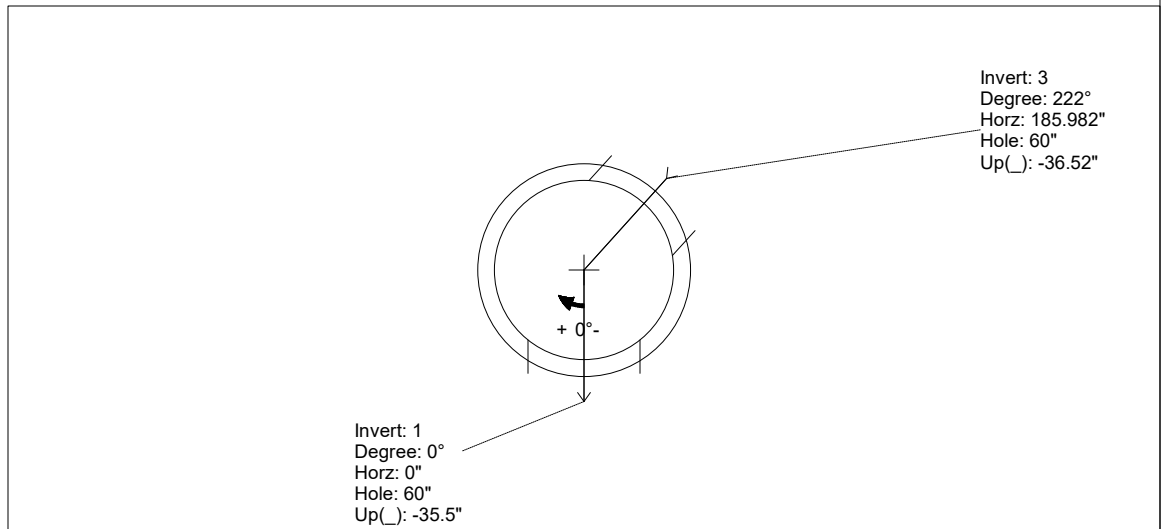
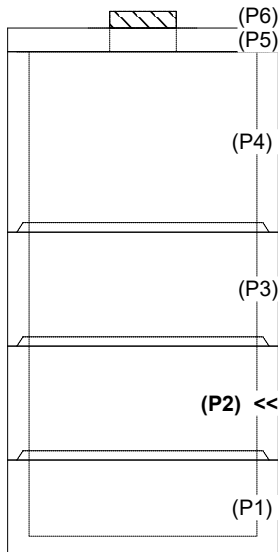

**INSIDE WALL DIMENSIONS**

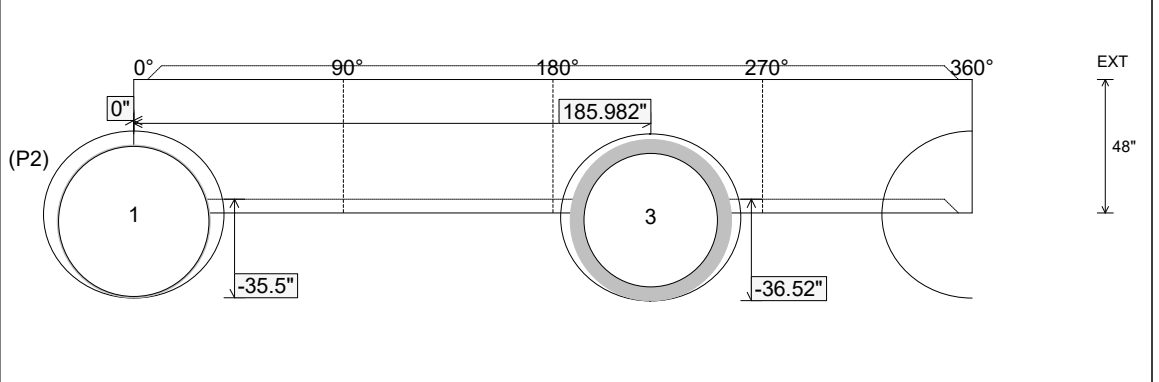

Coating (Int): Coating (Ext):	Seam Up: Tongue Seam Dn: Groove	Wall Thickness: 9" Floor Height: 0"	Height (Int): 48" Height (Ext): 48"	Weight (Net): 9778 lb Volume (Net): 2.5cu.yd
----------------------------------	------------------------------------	--	--	---