

Job Name: 25-2601 Spring Creek Parkway Phase 2 (Storm)  
 Job Location: Clarksville, TN  
 Contractor: Byard Construction, LLC

Plant: Beaver Dam  
 2/24/2026 10:38:59 AM

Tech: S. Felletter  
 PC: A. Chambers



**Structure ID: CB-44**

**P1 MH096BAVF**

**MH MONOBASE 8F, Custom Ht T/n**

- P5) 28" x 34" - CASTING HEIGHT - 7" 0 lb
- P4) 96" - MH FLAT TOP - TDOT NO 12 (28"x34" Hole) F/F - 10" 7767 lb
- P3) 96" - MH RISER Custom Ht F/G - 70" 17417 lb
- P2) 96" - MH RISER Custom Ht T/G - 70" 15157 lb
- P1) 96" - MH MONOBASE 8F, Custom Ht T/n - 32" 12550 lb
- 3) 96" - Conseal CS-102 1.00" 0 lb
- 1) 28" x 34" - Conseal CS-102 1.00" 0 lb
- 2) Hole - 60 0 lb
- 1) Hole - 6 0 lb

Structure Total: 52891 lb

**Structure Notes:**  
 1. PER TDOT D-CB-12RC / ASTM C478 SPEC'S.  
 2. CONCRETE = 4,000 PSI AT 28 DAYS.  
 3. NO INVERT CHANNEL.  
 4. CASTING BY OTHERS (TDOT TY. 12 - JBS 3123 MOD F/G/H).  
  
 REINFORCING PER ASTM A615 (GRADE 60).  
 \*\* PER TDOT STD DRAWING D-CB-12RC \*\*  
 - TOP SLAB - DBL MAT #5 BARS.  
 - RISER (As .18)  
 - FLOOR (As .62) #5 BARS AT 6" C.C.E.W.

Rim: 501.15' Rim to Invert: 15.36' Slack: 0.32" Sump: 5" Step Position:

GENERAL NOTES:

1. MANUFACTURED TO ASTM C-478 (LATEST REVISION).
2. CONCRETE 5,000 PSI AT 28 DAYS.
3. REINFORCING: WALLS - WWF AREA 0.24  
 FLOOR - AREA 0.27 - #5 BAR @ 12" C/C TOP AND BOTTOM MAT.
4. WEIGHT: TOTAL - 12,550 LBS.  
 FIRST POUR - 7,306 LBS  
 SECOND POUR - 5,244 LBS

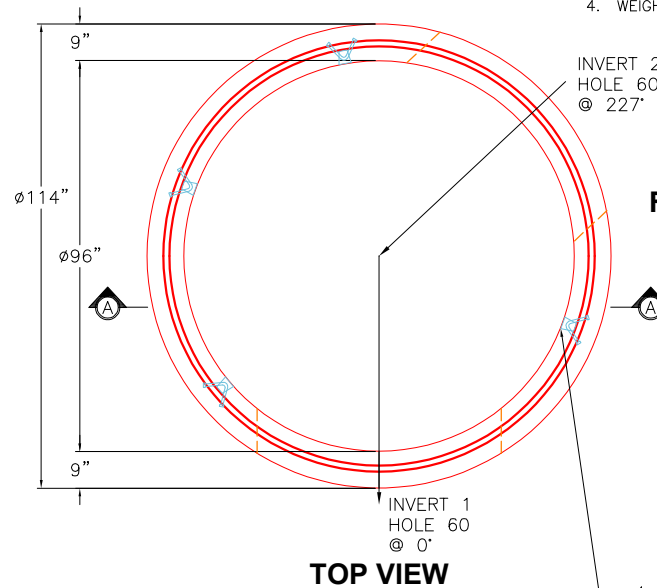

**FIRST POUR DRAWING**

4 EA. CONAC 6CA14 ANCHORS REQUIRED FOR HANDLING.

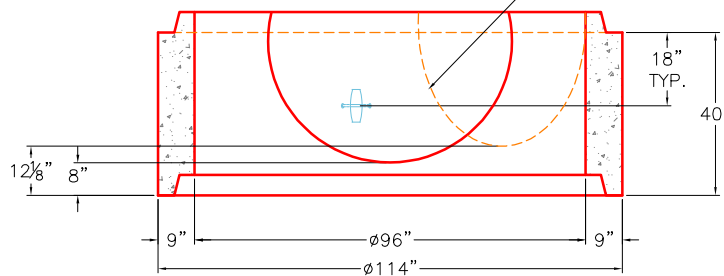

**SECTION A-A**

Coating (Int):  
 Coating (Ext):

Seam Up: Tongue  
 Seam Dn: n/a

Wall Thickness: 9"  
 Floor Height: 8"

Height (Int): 32"  
 Height (Ext): 40"

Weight (Net): 12550 lb  
 Volume (Net): 3.21cu.yd

Job Name: 25-2601 Spring Creek Parkway Phase 2 (Storm)  
 Job Location: Clarksville, TN  
 Contractor: Byard Construction, LLC

Plant: Beaver Dam  
 2/24/2026 10:38:59 AM

Tech: S. Felletter  
 PC: A. Chambers



**Structure ID: CB-44**

**P1 MH096BAVF**

**MH MONOBASE 8F, Custom Ht T/n**

P5) 28" x 34" - CASTING HEIGHT - 7"	0 lb
P4) 96" - MH FLAT TOP - TDOT NO 12 (28"x34" Hole) F/F - 10"	7767 lb
P3) 96" - MH RISER Custom Ht F/G - 70"	17417 lb
P2) 96" - MH RISER Custom Ht T/G - 70"	15157 lb
P1) 96" - MH MONOBASE 8F, Custom Ht T/n - 32"	12550 lb
3) 96" - Conseal CS-102 1.00"	0 lb
1) 28" x 34" - Conseal CS-102 1.00"	0 lb
2) Hole - 60	0 lb
1) Hole - 6	0 lb
<b>Structure Total:</b>	<b>52891 lb</b>

**Structure Notes:**  
 1. PER TDOT D-CB-12RC / ASTM C478 SPEC'S.  
 2. CONCRETE = 4,000 PSI AT 28 DAYS.  
 3. NO INVERT CHANNEL.  
 4. CASTING BY OTHERS (TDOT TY. 12 - JBS 3123 MOD F/G/H).  
  
 REINFORCING PER ASTM A615 (GRADE 60).  
 \*\* PER TDOT STD DRAWING D-CB-12RC \*\*  
 - TOP SLAB - DBL MAT #5 BARS.  
 - RISER (As .18)  
 - FLOOR (As .62) #5 BARS AT 6" C.C.E.W.

Rim: 501.15' Rim to Invert: 15.36' Slack: 0.32" Sump: 5" Step Position:

**GENERAL NOTES:**

1. MANUFACTURED TO ASTM C-478 (LATEST REVISION).
2. CONCRETE 5,000 PSI AT 28 DAYS.
3. REINFORCING: WALLS - WWF AREA 0.24  
 FLOOR - AREA 0.27 - #5 BAR @ 12" C/C TOP AND BOTTOM MAT.
4. WEIGHT: TOTAL - 12,550 LBS.  
 FIRST POUR - 7,306 LBS.  
 SECOND POUR - 5,244 LBS

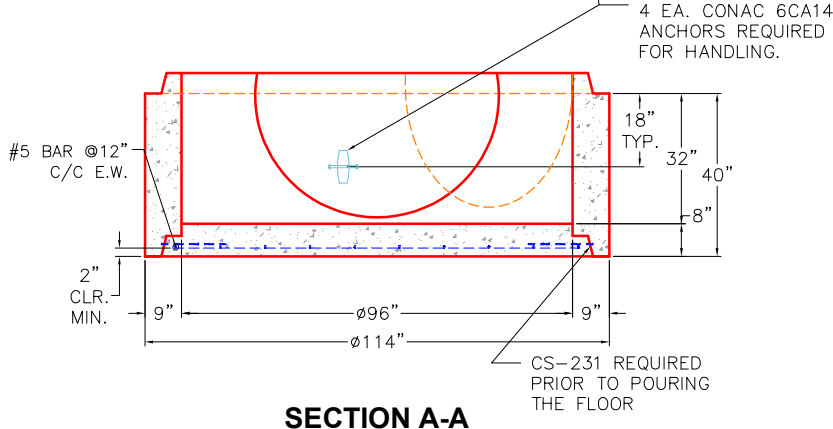
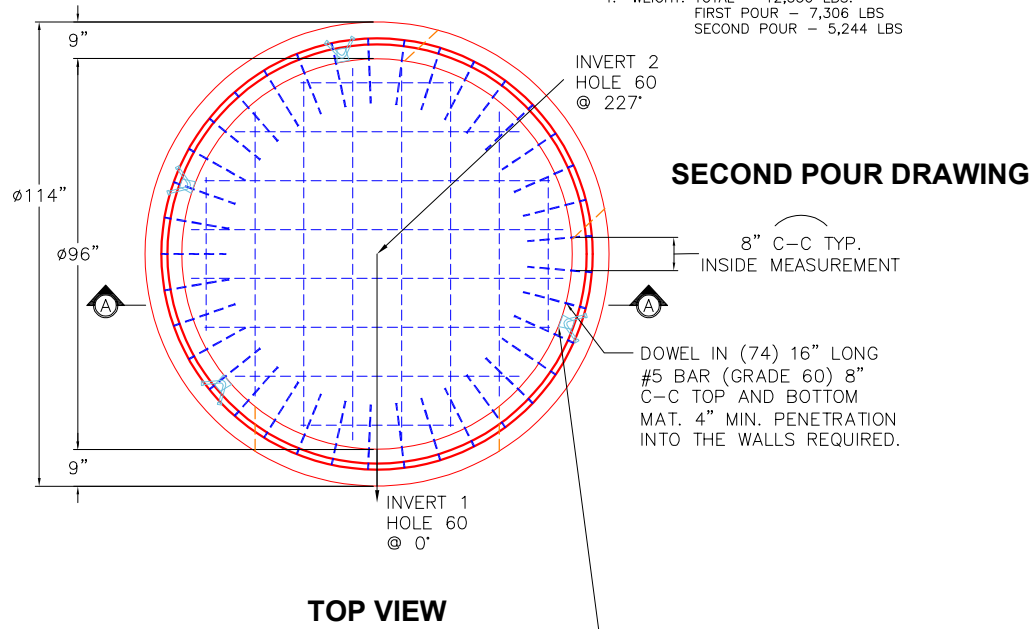

Coating (Int): Coating (Ext):	Seam Up: Tongue Seam Dn: n/a	Wall Thickness: 9" Floor Height: 8"	Height (Int): 32" Height (Ext): 40"	Weight (Net): 12550 lb Volume (Net): 3.21cu.yd
----------------------------------	---------------------------------	--	--	---