

Job Name: 25-2592 - Meadows-Northland Ph 7
 Job Location: Lexington, KY
 Contractor: Delmae LLC

Plant: 100

2/5/2026 2:17:02 PM

Tech: J. Horsley - F

PC: T. Lewis



Structure ID: S3

P1 MH048BA30

MH BASE F/n

- P3) 24" - CASTING HEIGHT - 7"
- P2) 48" - MH FLAT TOP w/ 24" ECC Hole F/F - 7"
- P1) 48" - MH BASE F/n - 30"
- 1) 48" - Conseal CS-102 1.00"
- 2) Hole - 32 x 22
- 2) Hole - 20

0 lb
 1286 lb
 2656 lb
 0 lb
 0 lb
 0 lb

 Structure Total: 3942 lb

Structure Notes:

1. PER ASTM C-478 SPECIFICATIONS
2. CONCRETE: 4,000 PSI AT 28 DAYS
3. REINFORCEMENT: PER ASTM A615
4. NO STORM INVERT
5. NO STEPS
6. HOE MC-350 FRAME & COVER "STORM" SUPPLIED BY OTHERS

Rim: 966.56' Rim to Invert: 3.49' Slack: 0.63" Sump: 2.75" Step Position:

Position	Elev	Angle	Ext. (cw)	Pipe	Pipe OD	Connector	Hole	Horz Size	Up ()	Offset
Invert 1	963.07'	0°	0"	23" x 14" ELL RCP	28.5" x 19.5"	Hole 32 x 22	32" x 22"	35.027"	0"	0"
Invert 2	963.1'	90°	45.553"	15" HDPE	17.6"	Hole 20	20"	20.629"	1.81"	0"
Invert 3	963.17'	180°	91.106"	23" x 14" ELL RCP	28.5" x 19.5"	Hole 32 x 22	32" x 22"	35.027"	1.2"	0"
Invert 4	963.1'	270°	136.659"	15" HDPE	17.6"	Hole 20	20"	20.629"	1.81"	0"
Invert 5										
Invert 6										
Invert 7										
Invert 8										

RIGHT-SIDE UP VIEW (int. dimensions)

UPSIDE-DOWN VIEW (int. dimensions)

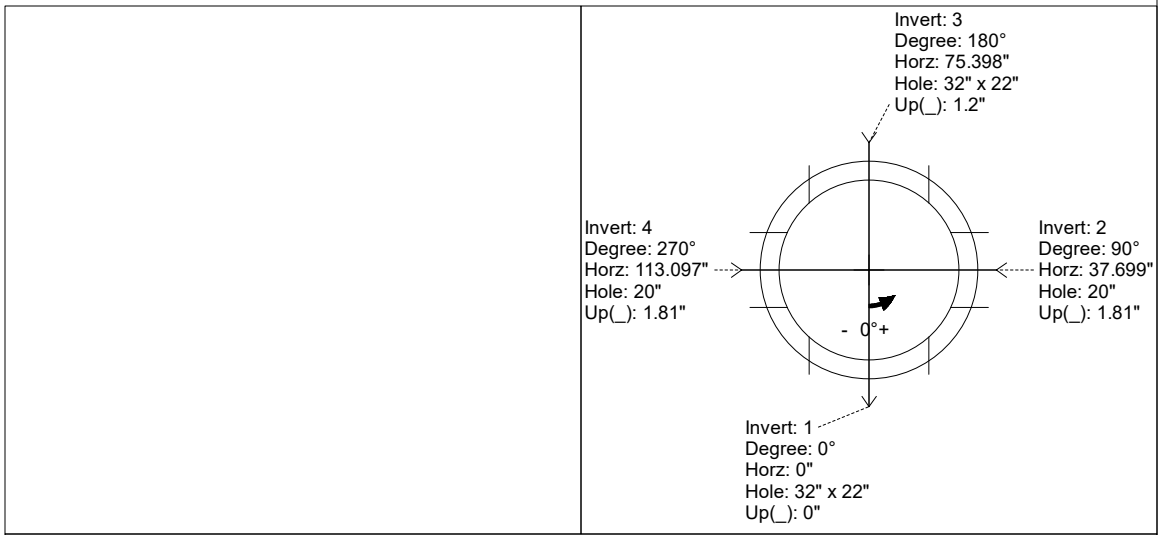
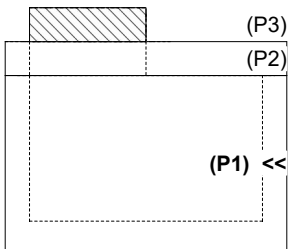

INSIDE WALL DIMENSIONS

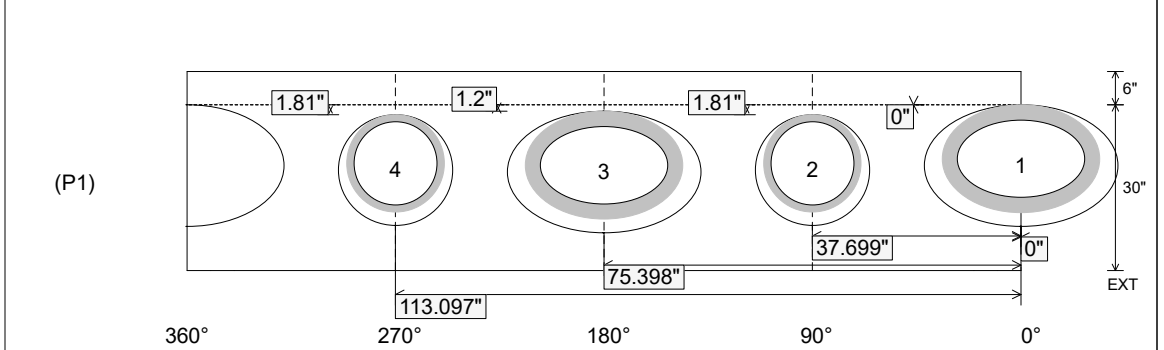

Coating (Int):
 Coating (Ext):

Seam Up: Flat
 Seam Dn: n/a

Wall Thickness: 5"
 Floor Height: 6"

Height (Int): 30"
 Height (Ext): 36"

Weight (Net): 2656 lb
 Volume (Net): 0.68cu.yd