

**PLAN VIEW  
(RIGHT SIDE UP)**

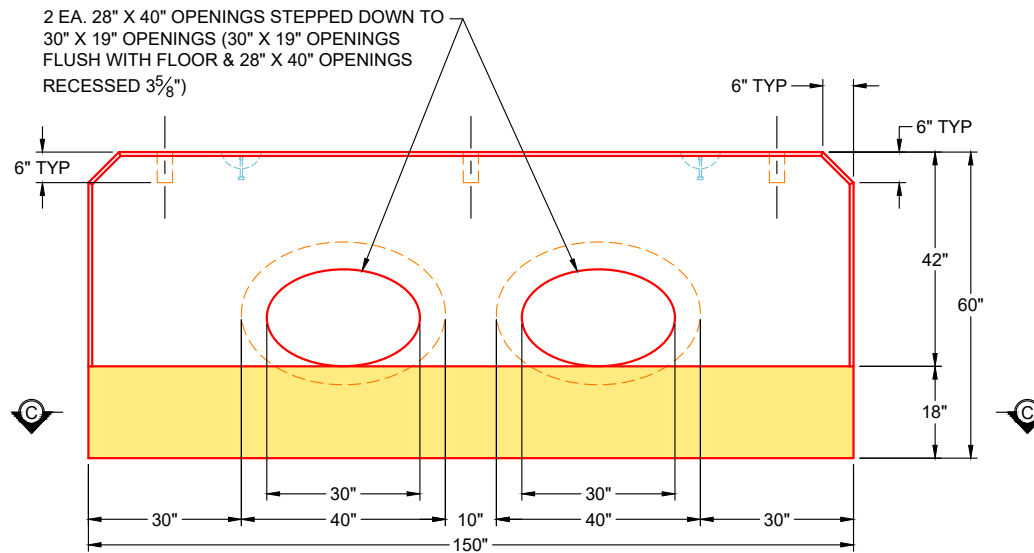

**FRONT VIEW  
(RIGHT SIDE UP)**

- GENERAL NOTES:**
1. CONCRETE: 5,000 PSI OR GREATER AT 28 DAYS
  2. REINFORCING: #5 BAR @ 12" C.C. E.W. (GRADE 60) - 2" MIN. REBAR CLEARANCE (TYP)  
- SEE SHEET 2 FOR REBAR LAYOUT & CUT LIST
  3. TOTAL WEIGHT: 12,895 LBS  
- FIRST POUR: 6,185 LBS  
- SECOND POUR: 6,710 LBS
  4. 3/4" CHAMFER ON ALL EXPOSED EDGES

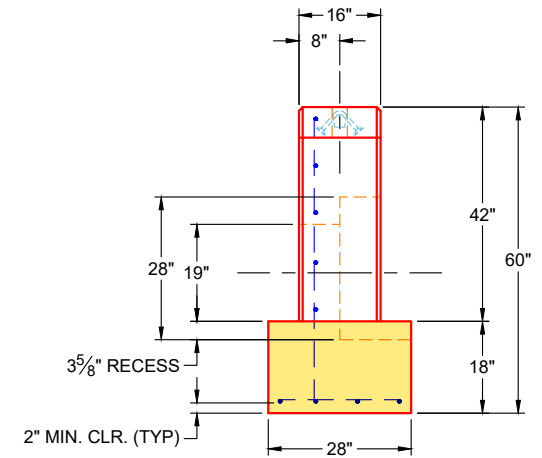

**SIDE VIEW  
(RIGHT SIDE UP)**

**PRODUCTION WORK ORDER**

PRODUCT I.D.: HWKYTC-STD1930D

DESCRIPTION: 19" X 30" KY DOUBLE STRAIGHT HW



**QUALITY CONTROL CHECKLIST**

- ALL DIMENSIONS CORRECT.
- LIFTERS INSTALLED.
- OPENING CENTERED.
- REINFORCING CORRECT.
- SURFACE QUALITY ACCEPTABLE.
- EDGES CHAMFERED.
- ALL PATCHWORK ACCEPTABLE.

PRODUCT VIEW: RIGHT SIDE UP

CUSTOMER: DELMAE, LLC

PLANT: BEAVER DAM, KY

PROJECT: MEADOWS-NORTHLAND PH 7

WEIGHT: 12,895 LBS

STRUCTURE: HDWL-1

TOP SECTION JOINT: N / A

ORDER NO: 25-2592

BASE SECTION JOINT: N / A

PE: J.H. ROSS

DRAWING: K. CARDWELL

QC CHECK INITIALS:

DATE: 02/05/26

SCALE: NTS

PG. 1 OF 2

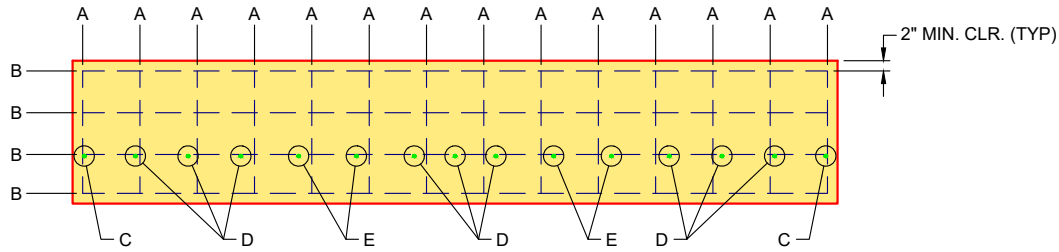

**SECTION C-C  
(RIGHT SIDE UP)**

**GENERAL NOTES:**

1. CONCRETE: 5,000 PSI OR GREATER AT 28 DAYS
2. REINFORCING: #5 BAR @ 12" C.C. E.W. (GRADE 60) - 2" MIN. REBAR CLEARANCE (TYP)  
- SEE THIS SHEET FOR REBAR LAYOUT & CUT LIST
3. TOTAL WEIGHT: 12,895 LBS  
- FIRST POUR: 6,185 LBS  
- SECOND POUR: 6,710 LBS
4. 3/4" CHAMFER ON ALL EXPOSED EDGES

**REBAR CUT LIST**

ITEM	LENGTH	SIZE	QTY.
A	24"	#5	14
B	146"	#5	7
C	52"	#5	2
D	56"	#5	9
E	19"	#5	4
F	31"	#5	2

ITEM	LENGTH	SIZE	QTY.
G	137"	#5	1
H	8"	#5	2
I	16"	#5	1
J	13"	#5	4
K	20"	#5	4

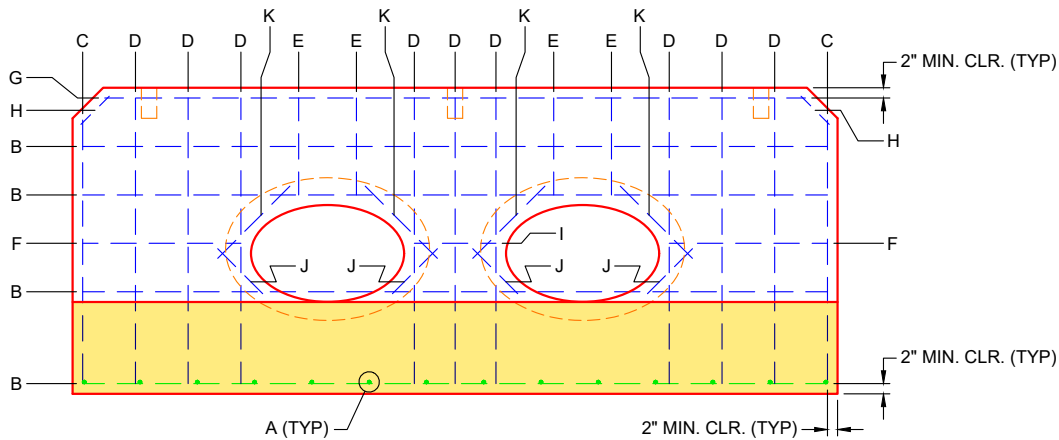

**SECTION A-A  
(RIGHT SIDE UP)**

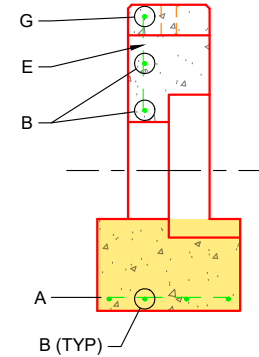

**SECTION B-B  
(RIGHT SIDE UP)**

**PRODUCTION WORK ORDER**

PRODUCT I.D.: HWKYTC-STD1930D

DESCRIPTION: 19" X 30" KY DOUBLE STRAIGHT HW - REBAR LAYOUT & CUT LIST



**QUALITY CONTROL CHECKLIST**

- ALL DIMENSIONS CORRECT.
- LIFTERS INSTALLED.
- OPENING CENTERED.
- REINFORCING CORRECT.
- SURFACE QUALITY ACCEPTABLE.
- EDGES CHAMFERED.
- ALL PATCHWORK ACCEPTABLE.

PRODUCT VIEW: RIGHT SIDE UP

CUSTOMER: DELMAE, LLC

PLANT: BEAVER DAM, KY

PROJECT: MEADOWS-NORTHLAND PH 7

WEIGHT: 12,895 LBS

STRUCTURE: HDWL-1

TOP SECTION JOINT: N / A

ORDER NO: 25-2592

BASE SECTION JOINT: N / A

PE: J.H. ROSS

DRAWING: K. CARDWELL

QC CHECK INITIALS:

DATE: 02/05/26

SCALE: NTS

PG. 2 OF 2

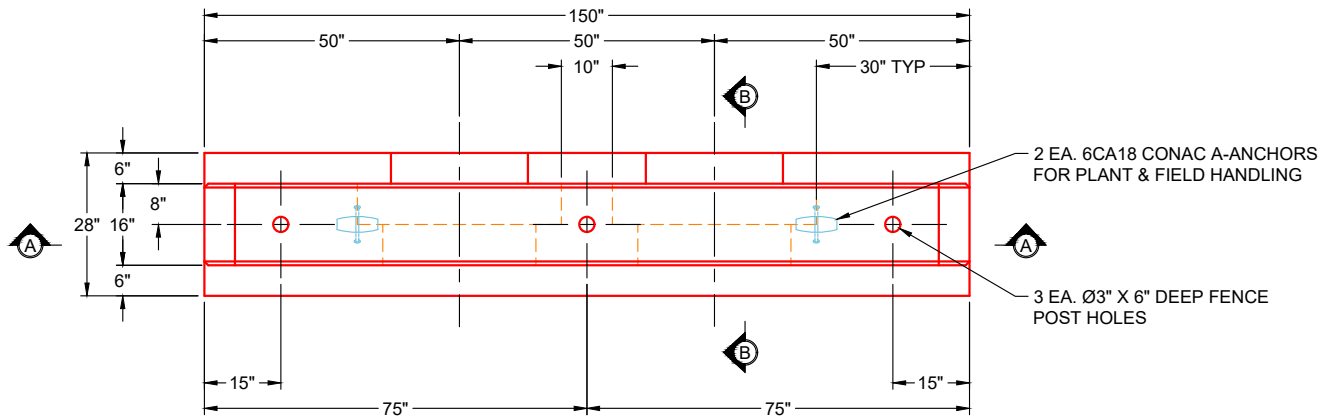

**PLAN VIEW  
(RIGHT SIDE UP)**

**GENERAL NOTES:**

1. CONCRETE: 5,000 PSI OR GREATER AT 28 DAYS
2. REINFORCING: #5 BAR @ 12" C.C. E.W. (GRADE 60) - 2" MIN. REBAR CLEARANCE (TYP) - SEE SHEET 2 FOR REBAR LAYOUT & CUT LIST
3. TOTAL WEIGHT: 12,895 LBS  
- FIRST POUR: 6,185 LBS  
- SECOND POUR: 6,710 LBS
4. 3/4" CHAMFER ON ALL EXPOSED EDGES

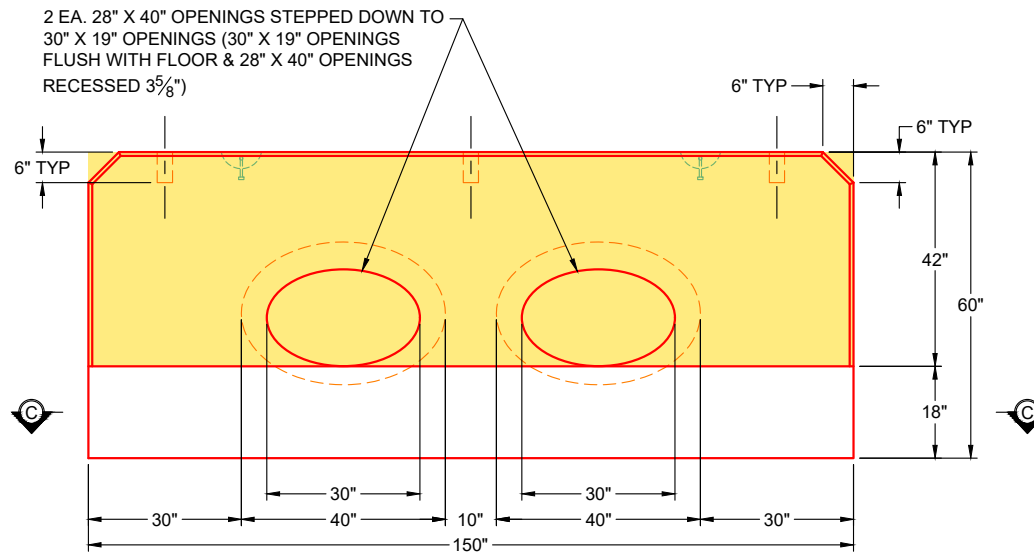

**FRONT VIEW  
(RIGHT SIDE UP)**

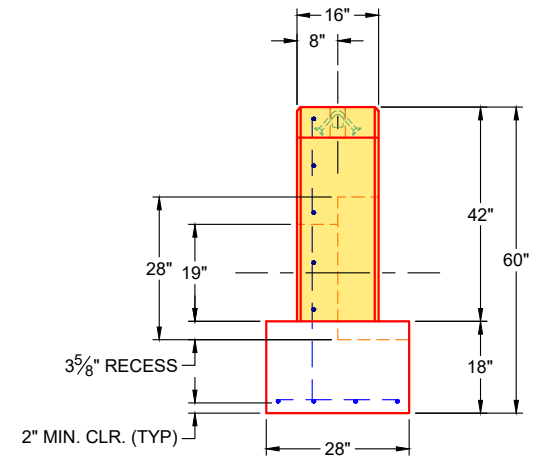

**SIDE VIEW  
(RIGHT SIDE UP)**

**PRODUCTION WORK ORDER**

PRODUCT I.D.: HWKYTC-STD1930D

DESCRIPTION: 19" X 30" KY DOUBLE STRAIGHT HW



**QUALITY CONTROL CHECKLIST**

- ALL DIMENSIONS CORRECT.
- LIFTERS INSTALLED.
- OPENING CENTERED.
- REINFORCING CORRECT.
- SURFACE QUALITY ACCEPTABLE.
- EDGES CHAMFERED.
- ALL PATCHWORK ACCEPTABLE.

PRODUCT VIEW: RIGHT SIDE UP

CUSTOMER: DELMAE, LLC

PLANT: BEAVER DAM, KY

PROJECT: MEADOWS-NORTHLAND PH 7

WEIGHT: 12,895 LBS

STRUCTURE: HDWL-1

TOP SECTION JOINT: N / A

ORDER NO: 25-2592

BASE SECTION JOINT: N / A

PE: J.H. ROSS

DRAWING: K. CARDWELL

QC CHECK INITIALS:

DATE: 02/05/26

SCALE: NTS

PG. 1 OF 2

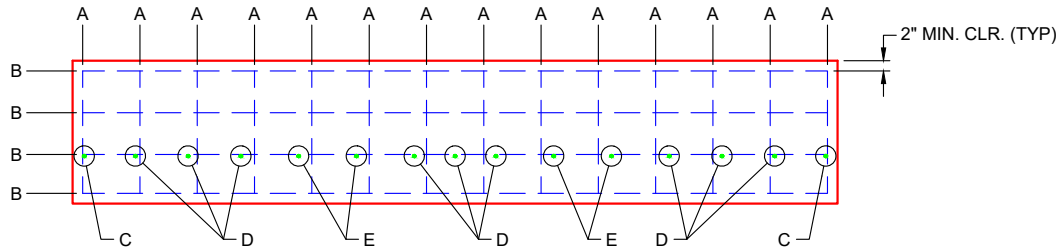

**SECTION C-C  
(RIGHT SIDE UP)**

**GENERAL NOTES:**

1. CONCRETE: 5,000 PSI OR GREATER AT 28 DAYS
2. REINFORCING: #5 BAR @ 12" C.C. E.W. (GRADE 60) - 2" MIN. REBAR CLEARANCE (TYP)  
- SEE THIS SHEET FOR REBAR LAYOUT & CUT LIST
3. TOTAL WEIGHT: 12,895 LBS  
- FIRST POUR: 6,185 LBS  
- SECOND POUR: 6,710 LBS
4. 3/4" CHAMFER ON ALL EXPOSED EDGES

**REBAR CUT LIST**

ITEM	LENGTH	SIZE	QTY.
A	24"	#5	14
B	146"	#5	7
C	52"	#5	2
D	56"	#5	9
E	19"	#5	4
F	31"	#5	2

ITEM	LENGTH	SIZE	QTY.
G	137"	#5	1
H	8"	#5	2
I	16"	#5	1
J	13"	#5	4
K	20"	#5	4

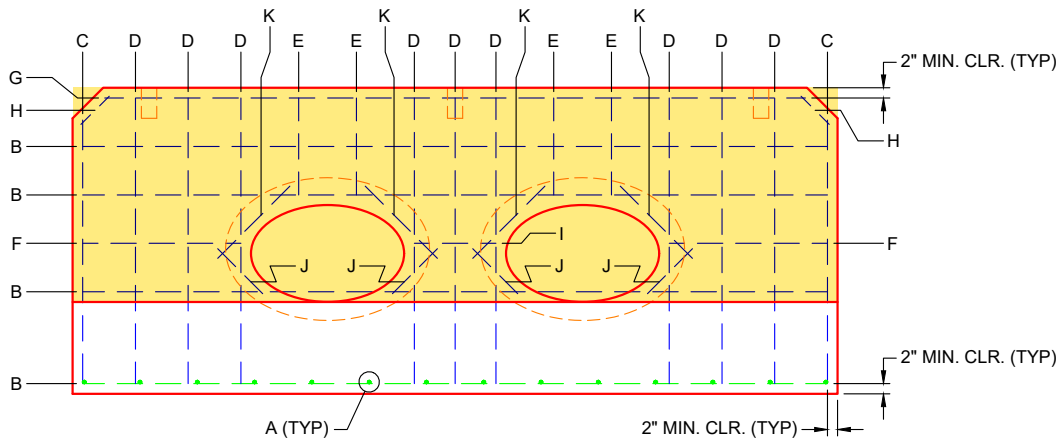

**SECTION A-A  
(RIGHT SIDE UP)**

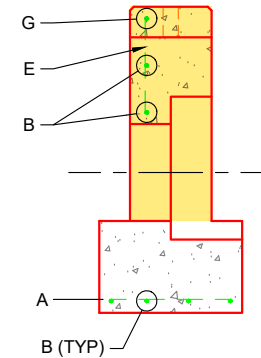

**SECTION B-B  
(RIGHT SIDE UP)**

**PRODUCTION WORK ORDER**

PRODUCT I.D.: HWKYC-STD1930D

DESCRIPTION: 19" X 30" KY DOUBLE STRAIGHT HW - REBAR LAYOUT & CUT LIST



**QUALITY CONTROL CHECKLIST**

- ALL DIMENSIONS CORRECT.
- LIFTERS INSTALLED.
- OPENING CENTERED.
- REINFORCING CORRECT.
- SURFACE QUALITY ACCEPTABLE.
- EDGES CHAMFERED.
- ALL PATCHWORK ACCEPTABLE.

PRODUCT VIEW: RIGHT SIDE UP

CUSTOMER: DELMAE, LLC

PLANT: BEAVER DAM, KY

PROJECT: MEADOWS-NORTHLAND PH 7

WEIGHT: 12,895 LBS

STRUCTURE: HDWL-1

TOP SECTION JOINT: N / A

ORDER NO: 25-2592

BASE SECTION JOINT: N / A

PE: J.H. ROSS

DRAWING: K. CARDWELL

QC CHECK INITIALS:

DATE: 02/05/26

SCALE: NTS

PG. 2 OF 2