

Job Name: 25-2511D Bluesky Sec. 1 (FORCE MAIN)
 Job Location: Clarksville, TN
 Contractor: Byard Construction, LLC

Plant: Beaver Dam
 10/21/2025 12:06:10 PM

Tech: J. Coppage
 PC: A. Chambers



Structure ID: WET WELL

P3 MH096RSVFCDR

MH RISER Custom Ht, w/ConBlock-CDA Red

- P4) 96" - MH FLAT TOP w/72" Hole ECC w/ConBlock-CDA Red - 17"
- P3) 96" - MH RISER Custom Ht, w/ConBlock-CDA Red - 80"
- P2) 96" - MH RISER Custom Ht, w/ConBlock-CDA Red - 96"
- P1) 96" - MH BASE (12"F) Custom Ht, w/ConBlock-CDA Red - 43"
- 1) JOINT WRAP - 12" WD x 096" MAC WRAP
- 3) 96" - BUTYL 1.00" CS-231 (DBL = 60' per joint)
- 1) PSX - 12-06 NYLO
- 1) PSX - 12-08 NYLO

6828 lb
 19844 lb
 23830 lb
 20990 lb
 0 lb
 0 lb
 8 lb
 8 lb

 Structure Total: 71507 lb

Structure Notes:

1. PER ASTM C478 SPECIFICATIONS.
2. CONCRETE = 4,500 PSI AT 28 DAYS.
3. ADMIXTURE = CONBLOCK CDA RED.
4. REINFORCING PER ASTM A615 (GRADE 60).
 - TOP SLAB (BY OTHERS)
 - RISER/WALLS (As .12)
 - FLOOR (As .31) #5 BARS AT 12" C.C.E.W.
6. VERIFY ALL ELEVATIONS.
7. EVERLAST PUMPING STATION BY OTHERS.

Rim: 500.6' Rim to Invert: 9.94' Slack: 0.4" Sump: 117.12" Step Position:

Position	Elev	Angle	Ext. (cw)	Pipe	Pipe OD	Connector	Hole	Horz Size	Up ()	Offset
Invert 1	493.8'	0°	0"	6" PVC SDR21	6.625"	PSX 12-06 NYLO	12"	12.031"	7.8"	0"
Invert 2										
Invert 3										
Invert 4										
Invert 5										
Invert 6										
Invert 7										
Invert 8										

RIGHT-SIDE UP VIEW (int. dimensions)

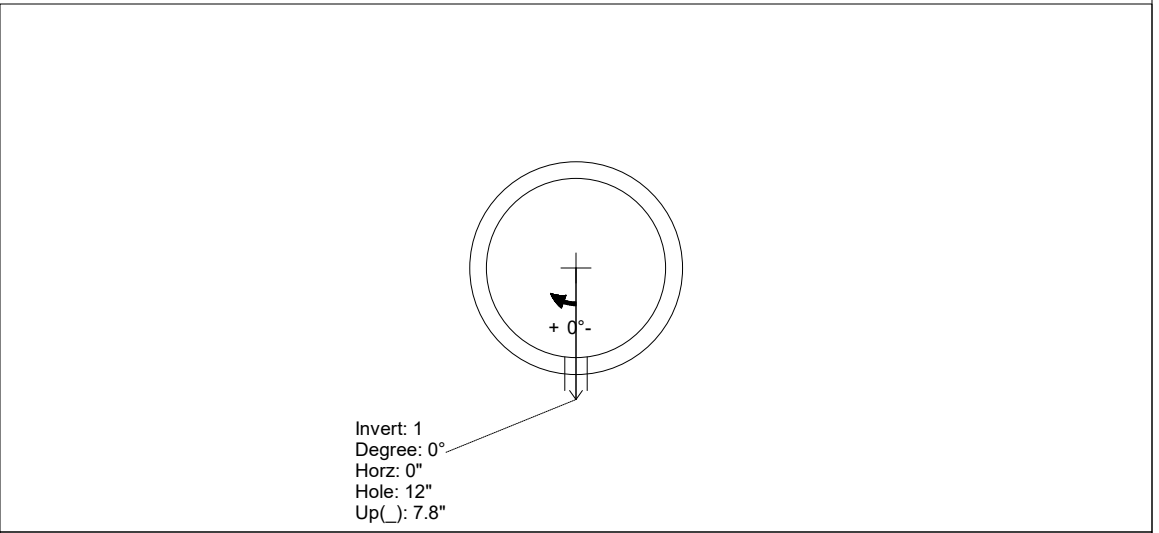
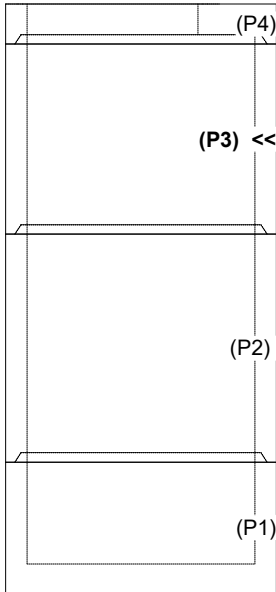

INSIDE WALL DIMENSIONS

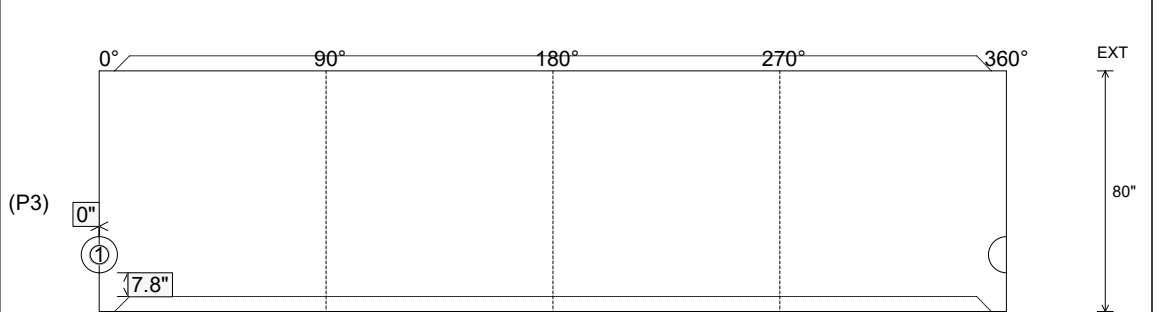

Coating (Int):
 Coating (Ext):

Seam Up: Tongue
 Seam Dn: Groove

Wall Thickness: 9"
 Floor Height: 0"

Height (Int): 80"
 Height (Ext): 80"

Weight (Net): 19844 lb
 Volume (Net): 5.07cu.yd