

Job Name: 25-2511C Blue Sky Sec. 1  
 Job Location: Clarksville, TN  
 Contractor: Byard Construction, LLC

Plant: Beaver Dam, KY  
 10/21/2025 1:51:36 PM

Tech: J. Copping  
 PC: Andrew Chamber



**Structure ID: SSMH-C4**

**P3 MH048CN42CDARED**

**ECC CONE w/ 24" HOLE, w/ConBlock-CDA Red**

- P5) 24" - CASTING HEIGHT - 6"
- P4) 24" - GRADE RING w/ConBlock-CDA Red - 3"
- P3) 48" - ECC CONE w/ 24" HOLE, w/ConBlock-CDA Red - 42"
- P2) 48" - MH RISER w/ConBlock-CDA Red - 60"
- P1) 48" - MH BASE w/ConBlock-CDA Red - 30"
- 1) 48" - MH INVERT CHANNEL - FULL HEIGHT
- 1) JOINT WRAP - 0.065"x6"x50' CONSEAL CS212
- 1) JOINT WRAP PRIMER - CONSEAL CS-75 (1 gal.)
- 1) CASTING - JBS 1155 F/C SANITARY
- 2) 48" - Conseal CS-102 1.00" (Double)
- 2) PSX - 12-08 NYLO
- 11) MH Step ML-10-TDS-NCR - 10"

- Structure Notes:**
1. PER ASTM C478 SPECIFICATIONS.
  2. CONCRETE = 4,000 PSI AT 28 DAYS.
  3. ADMIXTURE = CONBLOCK CDA RED.
  4. CASTING JBS 1155 "Sanitary" BY ICAST
- REINFORCING PER ASTM A615 (GRADE 60).
- CONE (As .12)
  - RISER/WALLS (As .12)
  - FLOOR (As .31) #5 BARS AT 12" C.C.E.W.

Structure Total: 12547 lb

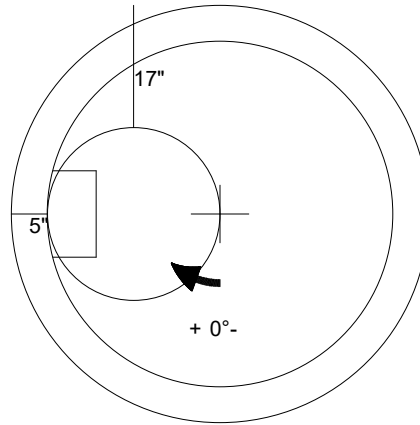

48" - ECC CONE w/ 24" HOLE, w/ConBlock-CDA Red - 42" - (P3)

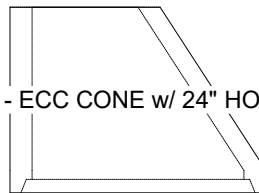

Coating (Int):  
 Coating (Ext):

Seam Up: Flat  
 Seam Dn: Groove

Wall Thickness: 5"

Height (Ext): 42"

Weight (Net): 3116 lb  
 Volume (Net): 0.8cu.yd