

Job Name: 25-2511C Blue Sky Sec. 1
Job Location: Clarksville, TN
Contractor: Byard Construction, LLC

PC: Andrew Chambers
 TECH: J. Coppage
 Plant: Beaver Dam, KY



Structure ID: **SSMH-C2**

Spec: Sanitary
 Type: SAN.MH w/ConBlock-CDA Red
 Size: 48"

Rim: 513.67'
 Invert: 503.49'
 Rim to Invert: 10.18'

Sump: 2"
 Floor (Top): 503.323'
 Floor Height: 6"

Floor (Bot): 502.823'
 Overall Height: 10.833'
 Slack: 0.16"

Structure Notes:

- PER ASTM C478 SPECIFICATIONS.
- CONCRETE = 4,000 PSI AT 28 DAYS.
- ADMIXTURE = CONBLOCK CDA RED.
- CASTING JBS 1155 "Sanitary" BY ICAST

REINFORCING PER ASTM A615 (GRADE 60).
 - CONE (As .12)
 - RISER/WALLS (As .12)
 - FLOOR (As .31) #5 BARS AT 12" C.C.E.W.

STRUCTURE SUMMARY:

P5) 24" - CASTING HEIGHT - 6"	0 lb
P4) 24" - GRADE RING w/ConBlock-CDA Red - 4"	270 lb
P3) 48" - ECC CONE w/ 24" HOLE, w/ConBlock-CDA Red - 24"	1738 lb
P2) 48" - MH RISER w/ConBlock-CDA Red - 60"	4192 lb
P1) 48" - MH BASE w/ConBlock-CDA Red - 30"	3330 lb
1) 48" - MH INVERT CHANNEL - FULL HEIGHT	1440 lb
1) JOINT WRAP - 0.065"x6"x50' CONSEAL CS212	0 lb
1) JOINT WRAP PRIMER - CONSEAL CS-75 (1 gal.)	0 lb
1) CASTING - JBS 1155 F/C SANITARY	250 lb
2) 48" - Conseal CS-102 1.00" (Double)	0 lb
2) PSX - 12-08 NYLO	16 lb
9) MH Step ML-10-TDS-NCR - 10"	0 lb
Structure Total:	11236 lb

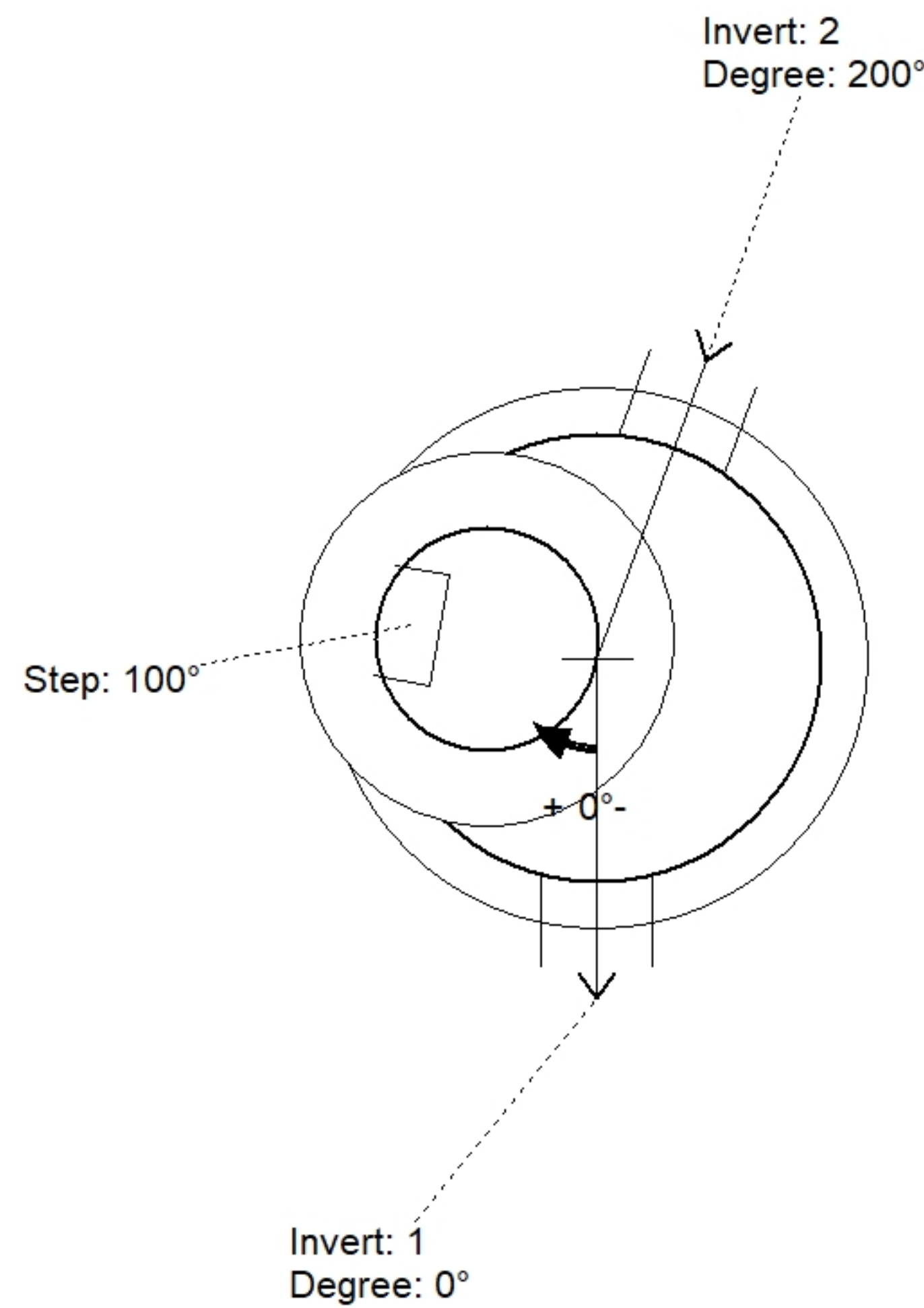

Position	Elev	Angle	Pipe	Pipe OD	Hole	Connector	Up (")	Ref
Rim	513.67'							
Reducer								
Invert 1	503.49'	0°	8" PVC SDR35	8.5"	12"	PSX 12-08 NYLO	0"	P1
Invert 2	503.59'	200°	8" PVC SDR35	8.5"	12"	PSX 12-08 NYLO	1.2"	P1
Invert 3								
Invert 4								
Invert 5								
Invert 6								
Invert 7								
Invert 8								

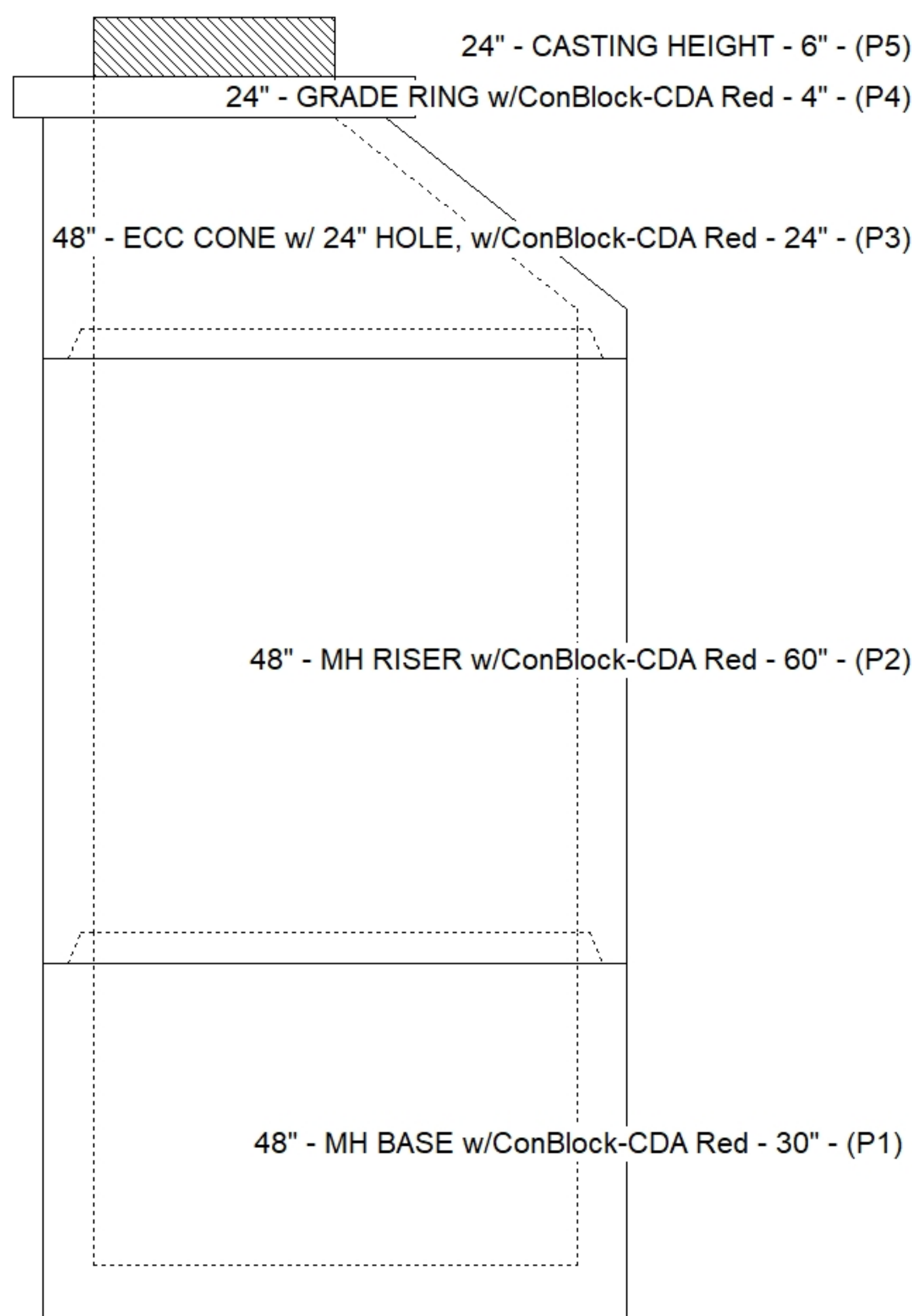

Default - Interior Dimensions

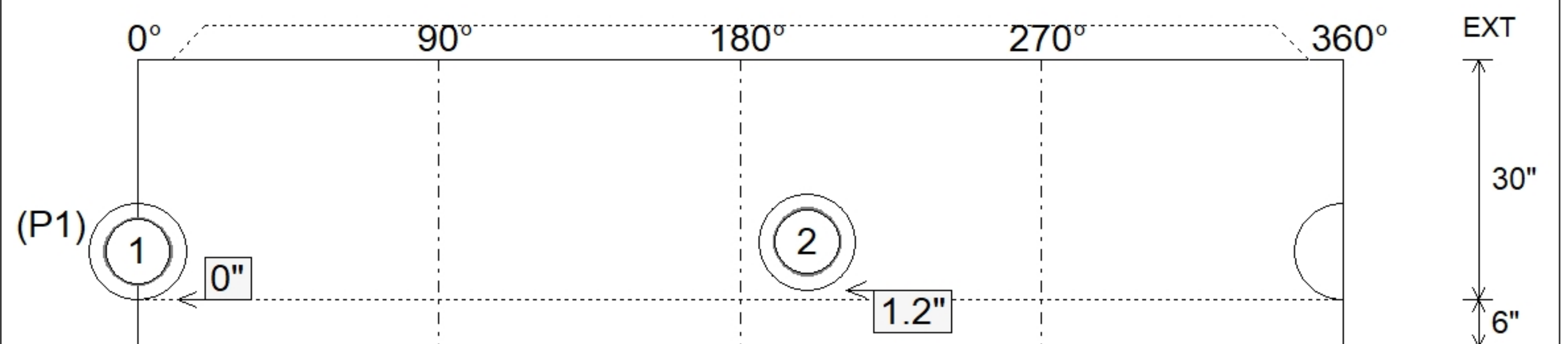

Submittal Drawing
 10/23/2025 7:55:21 AM

SUBMITTAL
 APPROVED BY: