

Job Name: 25-2511C Blue Sky Sec. 1
 Job Location: Clarksville, TN
 Contractor: Byard Construction, LLC

Plant: Beaver Dam, KY

10/21/2025 1:51:35 PM

Tech: J. Coppage

PC: Andrew Chamber



Structure ID: SSMH-C1

P3 MH048CN36CDARED

ECC CONE w/ 24" HOLE, w/ConBlock-CDA Red

- P4) 24" - CASTING HEIGHT - 6"
- P3) 48" - ECC CONE w/ 24" HOLE, w/ConBlock-CDA Red - 36"
- P2) 48" - MH RISER w/ConBlock-CDA Red - 24"
- P1) 48" - MH BASE w/ConBlock-CDA Red - 24"
- 1) 48" - MH INVERT CHANNEL - FULL HEIGHT
- 1) JOINT WRAP - 0.065"x6"x50' CONSEAL CS212
- 1) JOINT WRAP PRIMER - CONSEAL CS-75 (1 gal.)
- 1) CASTING - JBS 1155 F/C SANITARY
- 2) 48" - Conseal CS-102 1.00" (Double)
- 3) PSX - 12-08 NYLO
- 7) MH Step ML-10-TDS-NCR - 10"

- | | |
|---|--|
| <ul style="list-style-type: none"> 0 lb 2251 lb 1677 lb 2863 lb 1440 lb 0 lb 0 lb 250 lb 0 lb 24 lb 0 lb | <p><u>Structure Notes:</u></p> <ol style="list-style-type: none"> 1. PER ASTM C478 SPECIFICATIONS. 2. CONCRETE = 4,000 PSI AT 28 DAYS. 3. ADMIXTURE = CONBLOCK CDA RED. 4. CASTING JBS 1155 "Sanitary" BY ICAST <p>REINFORCING PER ASTM A615 (GRADE 60).</p> <ul style="list-style-type: none"> - CONE (As .12) - RISER/WALLS (As .12) - FLOOR (As .31) #5 BARS AT 12" C.C.E.W. |
|---|--|

Structure Total: 8505 lb

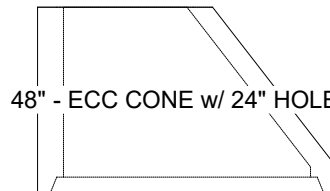
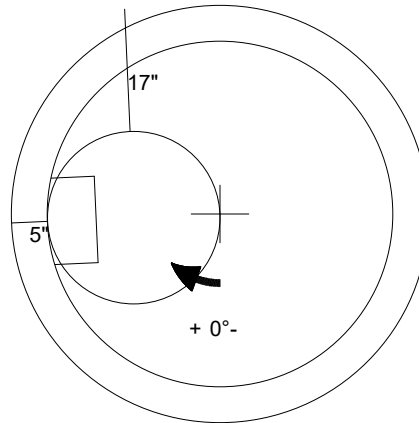

48" - ECC CONE w/ 24" HOLE, w/ConBlock-CDA Red - 36" - (P3)

Coating (Int):
 Coating (Ext):

Seam Up: Flat
 Seam Dn: Groove

Wall Thickness: 5"

Height (Ext): 36"

Weight (Net): 2251 lb
 Volume (Net): 0.57cu.yd