

Job Name: 25-2511C Blue Sky Sec. 1
 Job Location: Clarksville, TN
 Contractor: Byard Construction, LLC

Plant: Beaver Dam, KY
 10/21/2025 1:50:36 PM

Tech: J. Coppage
 PC: Andrew Chamber



Structure ID: SSMH-B6

P1 MH048BA24CDARED

MH BASE w/ConBlock-CDA Red

- P3) 24" - CASTING HEIGHT - 6"
- P2) 48" - ECC CONE w/ 24" HOLE, w/ConBlock-CDA Red - 30"
- P1) 48" - MH BASE w/ConBlock-CDA Red - 24"
- 1) 48" - MH INVERT CHANNEL - FULL HEIGHT
- 1) JOINT WRAP - 0.065"x6"x50' CONSEAL CS212
- 1) JOINT WRAP PRIMER - CONSEAL CS-75 (1 gal.)
- 1) CASTING - JBS 1155 F/C SANITARY
- 1) 48" - Conseal CS-102 1.00" (Double)
- 1) PSX - 12-08 NYLO
- 5) MH Step ML-10-TDS-NCR - 10"

- Structure Notes:**
1. PER ASTM C478 SPECIFICATIONS.
 2. CONCRETE = 4,000 PSI AT 28 DAYS.
 3. ADMIXTURE = CONBLOCK CDA RED.
 4. CASTING JBS 1155 "Sanitary" BY ICAST
- REINFORCING PER ASTM A615 (GRADE 60).
- CONE (As .12)
 - RISER/WALLS (As .12)
 - FLOOR (As .31) #5 BARS AT 12" C.C.E.W.

Structure Total: 6618 lb

Rim: 516.83' Rim to Invert: 4.92' Slack: 1.04" Sump: 2" Step Position: 180°

Position	Elev	Angle	Ext. (cw)	Pipe	Pipe OD	Connector	Hole	Horz Size	Up ()	Offset
Invert 1	511.91'	0°	0"	8" PVC SDR35	8.5"	PSX 12-08 NYLO	12"	12.129"	0"	0"
Invert 2										
Invert 3										
Invert 4										
Invert 5										
Invert 6										
Invert 7										
Invert 8										

RIGHT-SIDE UP VIEW (int. dimensions)

UPSIDE-DOWN VIEW (int. dimensions)

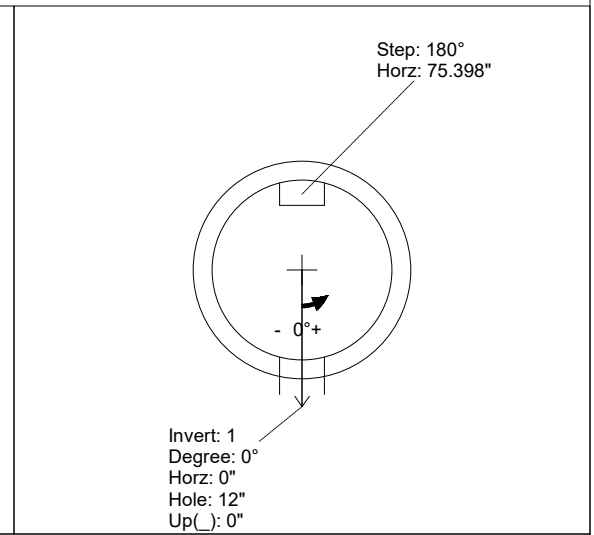
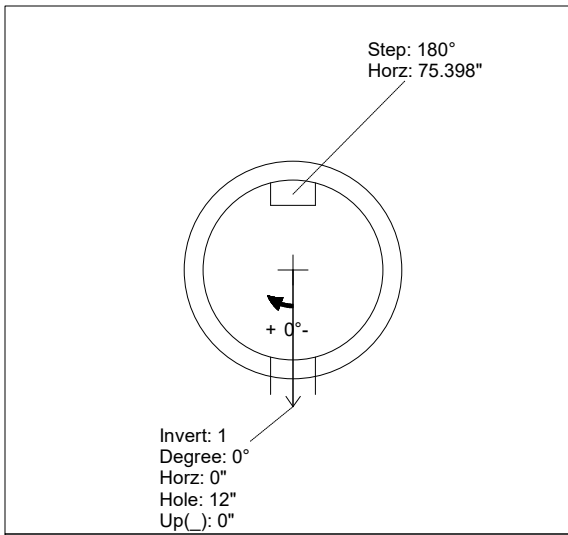
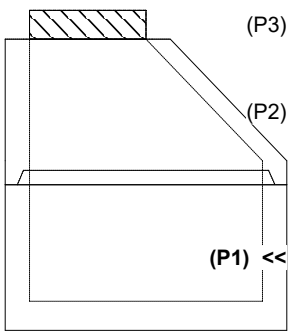

INSIDE WALL DIMENSIONS

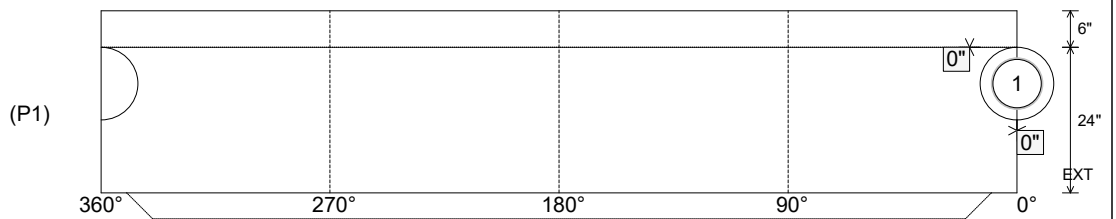

Coating (Int): Coating (Ext):	Seam Up: Tongue Seam Dn: n/a	Wall Thickness: 5" Floor Height: 6"	Height (Int): 24" Height (Ext): 30"	Weight (Net): 2959 lb Volume (Net): 0.76cu.yd
----------------------------------	---------------------------------	--	--	--

Job Name: 25-2511C Blue Sky Sec. 1
 Job Location: Clarksville, TN
 Contractor: Byard Construction, LLC

Plant: Beaver Dam, KY
 10/21/2025 1:50:36 PM

Tech: J. Coppage
 PC: Andrew Chamber



Structure ID: SSMH-B6

P1 MH048BA24CDARED

MH BASE w/ConBlock-CDA Red

- P3) 24" - CASTING HEIGHT - 6"
- P2) 48" - ECC CONE w/ 24" HOLE, w/ConBlock-CDA Red - 30"
- P1) 48" - MH BASE w/ConBlock-CDA Red - 24"
- 1) 48" - MH INVERT CHANNEL - FULL HEIGHT
- 1) JOINT WRAP - 0.065"x6"x50' CONSEAL CS212
- 1) JOINT WRAP PRIMER - CONSEAL CS-75 (1 gal.)
- 1) CASTING - JBS 1155 F/C SANITARY
- 1) 48" - Conseal CS-102 1.00" (Double)
- 1) PSX - 12-08 NYLO
- 5) MH Step ML-10-TDS-NCR - 10"

- Structure Notes:**
1. PER ASTM C478 SPECIFICATIONS.
 2. CONCRETE = 4,000 PSI AT 28 DAYS.
 3. ADMIXTURE = CONBLOCK CDA RED.
 4. CASTING JBS 1155 "Sanitary" BY ICAST
- REINFORCING PER ASTM A615 (GRADE 60).
- CONE (As .12)
 - RISER/WALLS (As .12)
 - FLOOR (As .31) #5 BARS AT 12" C.C.E.W.

Structure Total: 6618 lb

**INVERT CHANNEL DRAWING
 FULL HEIGHT INVERT**

Rim: 516.83' Rim to Invert: 4.92' Slack: 1.04" Sump: 2" Step Position: 180°

Position	Elev	Angle	Ext. (cw)	Pipe	Pipe OD	Connector	Hole	Horz Size	Up ()	Offset
Invert 1	511.91'	0°	0"	8" PVC SDR35	8.5"	PSX 12-08 NYLO	12"	12.129"	0"	0"
Invert 2										
Invert 3										
Invert 4										
Invert 5										
Invert 6										
Invert 7										
Invert 8										

RIGHT-SIDE UP VIEW (int. dimensions)

UPSIDE-DOWN VIEW (int. dimensions)

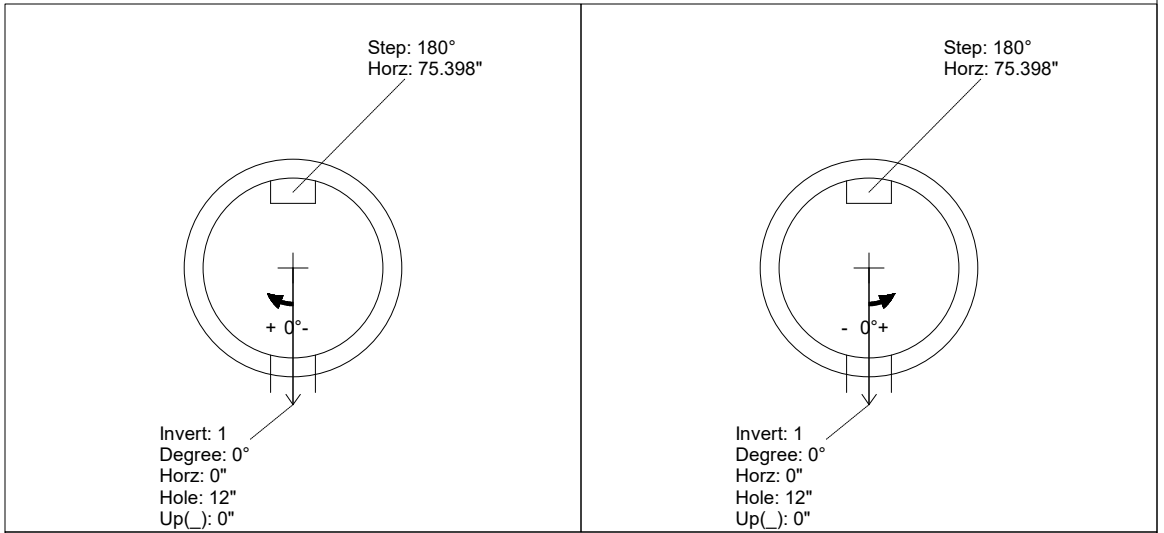
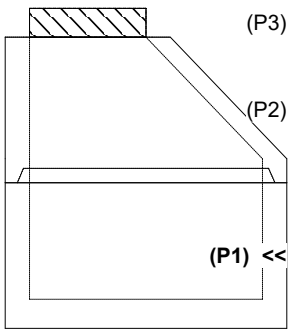

INSIDE WALL DIMENSIONS

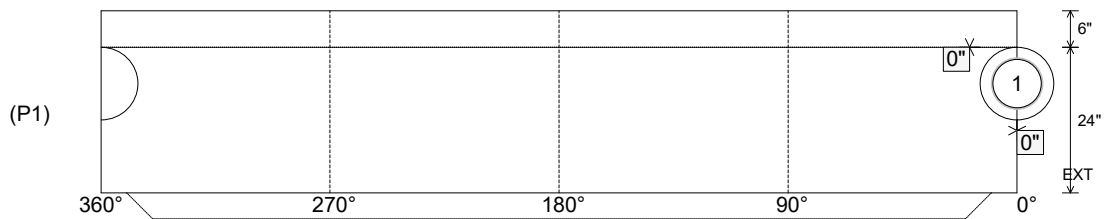

Coating (Int):
 Coating (Ext):

Seam Up: Tongue
 Seam Dn: n/a

Wall Thickness: 5"
 Floor Height: 6"

Height (Int): 24"
 Height (Ext): 30"

Weight (Net): 2959 lb
 Volume (Net): 0.76cu.yd