

Job Name: 25-2511C Blue Sky Sec. 1  
 Job Location: Clarksville, TN  
 Contractor: Byard Construction, LLC

Plant: Beaver Dam, KY  
 10/21/2025 1:50:35 PM

Tech: J. Coppage  
 PC: Andrew Chamber



**Structure ID: SSMH-B5**

**P1 MH048BA24CDARED**

**MH BASE w/ConBlock-CDA Red**

- P4) 24" - CASTING HEIGHT - 6"
- P3) 48" - ECC CONE w/ 24" HOLE, w/ConBlock-CDA Red - 36"
- P2) 48" - MH RISER w/ConBlock-CDA Red - 36"
- P1) 48" - MH BASE w/ConBlock-CDA Red - 24"
- 1) 48" - MH INVERT CHANNEL - FULL HEIGHT
- 1) JOINT WRAP - 0.065"x6"x50' CONSEAL CS212
- 1) JOINT WRAP PRIMER - CONSEAL CS-75 (1 gal.)
- 1) CASTING - JBS 1155 F/C SANITARY
- 2) 48" - Conseal CS-102 1.00" (Double)
- 3) PSX - 12-08 NYLO
- 1) PSX - 8QRS-S NYLO
- 8) MH Step ML-10-TDS-NCR - 10"

- Structure Notes:**
1. PER ASTM C478 SPECIFICATIONS.
  2. CONCRETE = 4,000 PSI AT 28 DAYS.
  3. ADMIXTURE = CONBLOCK CDA RED.
  4. CASTING JBS 1155 "Sanitary" BY ICAST
- REINFORCING PER ASTM A615 (GRADE 60).
- CONE (As .12)
  - RISER/WALLS (As .12)
  - FLOOR (As .31) #5 BARS AT 12" C.C.E.W.

Structure Total: 9329 lb

Rim: 519.67' Rim to Invert: 8.52' Slack: 2.24" Sump: 2" Step Position: 45°

Position	Elev	Angle	Ext. (cw)	Pipe	Pipe OD	Connector	Hole	Horz Size	Up ( )	Offset
Invert 1	511.15'	0°	0"	8" PVC SDR35	8.5"	PSX 12-08 NYLO	12"	12.129"	0"	0"
Invert 2	511.25'	90°	45.553"	8" PVC SDR35	8.5"	PSX 12-08 NYLO	12"	12.129"	1.2"	0"
Invert 3	511.25'	180°	91.106"	4" PVC SDR35	4.25"	PSX 8QRS-S NYLO	8"	8.038"	1.2"	0"
Invert 4	511.25'	270°	136.659"	8" PVC SDR35	8.5"	PSX 12-08 NYLO	12"	12.129"	1.2"	0"
Invert 5										
Invert 6										
Invert 7										
Invert 8										

RIGHT-SIDE UP VIEW (int. dimensions)

UPSIDE-DOWN VIEW (int. dimensions)

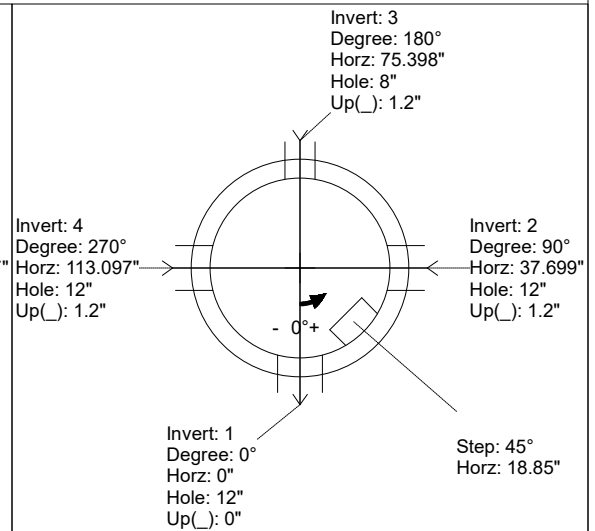
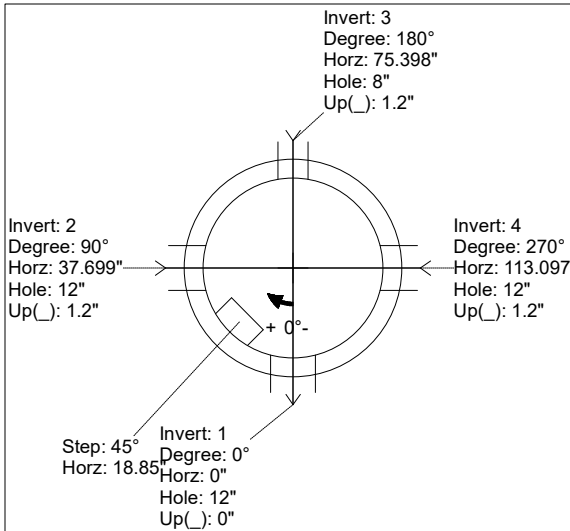
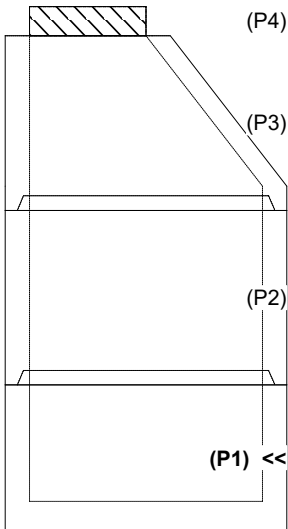

INSIDE WALL DIMENSIONS

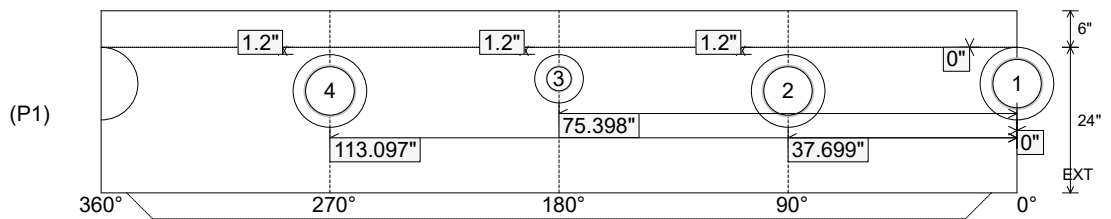

Coating (Int): Coating (Ext):	Seam Up: Tongue Seam Dn: n/a	Wall Thickness: 5" Floor Height: 6"	Height (Int): 24" Height (Ext): 30"	Weight (Net): 2842 lb Volume (Net): 0.73cu.yd
----------------------------------	---------------------------------	--	--	--

Job Name: 25-2511C Blue Sky Sec. 1  
 Job Location: Clarksville, TN  
 Contractor: Byard Construction, LLC

Plant: Beaver Dam, KY  
 10/21/2025 1:50:35 PM

Tech: J. Coppage  
 PC: Andrew Chambe



**Structure ID: SSMH-B5**

**P1 MH048BA24CDARED**

**MH BASE w/ConBlock-CDA Red**

- P4) 24" - CASTING HEIGHT - 6"
- P3) 48" - ECC CONE w/ 24" HOLE, w/ConBlock-CDA Red - 36"
- P2) 48" - MH RISER w/ConBlock-CDA Red - 36"
- P1) 48" - MH BASE w/ConBlock-CDA Red - 24"
- 1) 48" - MH INVERT CHANNEL - FULL HEIGHT
- 1) JOINT WRAP - 0.065"x6"x50' CONSEAL CS212
- 1) JOINT WRAP PRIMER - CONSEAL CS-75 (1 gal.)
- 1) CASTING - JBS 1155 F/C SANITARY
- 2) 48" - Conseal CS-102 1.00" (Double)
- 3) PSX - 12-08 NYLO
- 1) PSX - 8QRS-S NYLO
- 8) MH Step ML-10-TDS-NCR - 10"

- Structure Notes:**
1. PER ASTM C478 SPECIFICATIONS.
  2. CONCRETE = 4,000 PSI AT 28 DAYS.
  3. ADMIXTURE = CONBLOCK CDA RED.
  4. CASTING JBS 1155 "Sanitary" BY ICAST
- REINFORCING PER ASTM A615 (GRADE 60).
- CONE (As .12)
  - RISER/WALLS (As .12)
  - FLOOR (As .31) #5 BARS AT 12" C.C.E.W.

Structure Total: 9329 lb

**INVERT CHANNEL DRAWING  
 FULL HEIGHT INVERT**

Rim: 519.67' Rim to Invert: 8.52' Slack: 2.24" Sump: 2" Step Position: 45°

Position	Elev	Angle	Ext. (cw)	Pipe	Pipe OD	Connector	Hole	Horz Size	Up ( )	Offset
Invert 1	511.15'	0°	0"	8" PVC SDR35	8.5"	PSX 12-08 NYLO	12"	12.129"	0"	0"
Invert 2	511.25'	90°	45.553"	8" PVC SDR35	8.5"	PSX 12-08 NYLO	12"	12.129"	1.2"	0"
Invert 3	511.25'	180°	91.106"	4" PVC SDR35	4.25"	PSX 8QRS-S NYLO	8"	8.038"	1.2"	0"
Invert 4	511.25'	270°	136.659"	8" PVC SDR35	8.5"	PSX 12-08 NYLO	12"	12.129"	1.2"	0"
Invert 5										
Invert 6										
Invert 7										
Invert 8										

RIGHT-SIDE UP VIEW (int. dimensions)

UPSIDE-DOWN VIEW (int. dimensions)

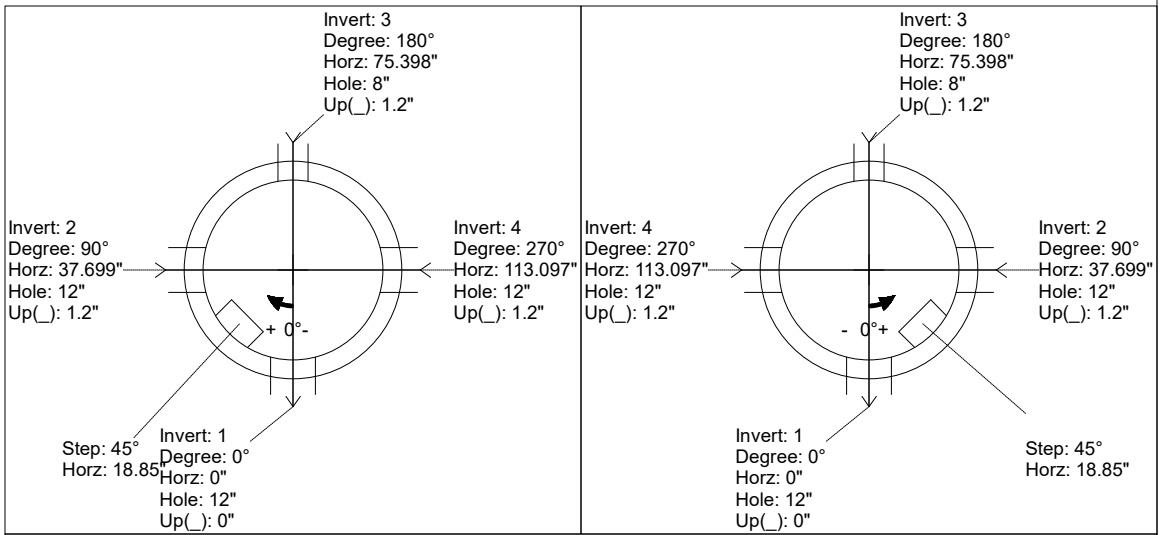
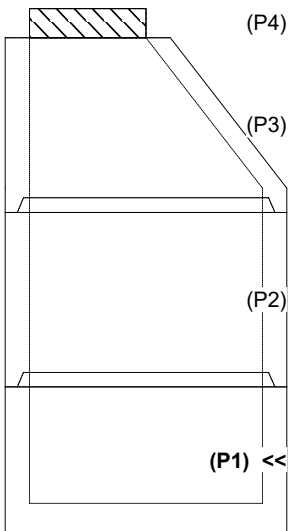

INSIDE WALL DIMENSIONS

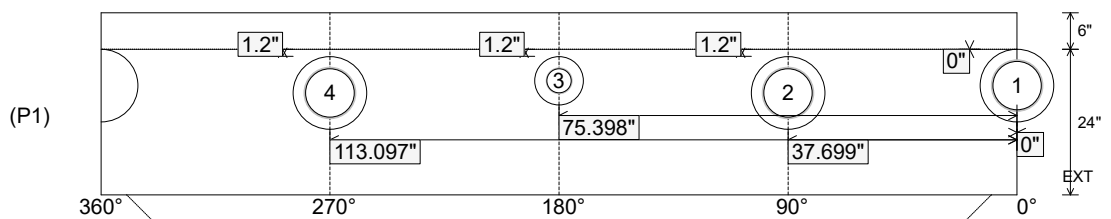

Coating (Int): Coating (Ext):	Seam Up: Tongue Seam Dn: n/a	Wall Thickness: 5" Floor Height: 6"	Height (Int): 24" Height (Ext): 30"	Weight (Net): 2842 lb Volume (Net): 0.73cu.yd
----------------------------------	---------------------------------	--	--	--