

Job Name: 25-2511C Blue Sky Sec. 1
 Job Location: Clarksville, TN
 Contractor: Byard Construction, LLC

Plant: Beaver Dam, KY
 10/21/2025 1:51:33 PM

Tech: J. Coppage
 PC: Andrew Chamber



Structure ID: SSMH-B3

P2 MH048CN30CDARED

ECC CONE w/ 24" HOLE, w/ConBlock-CDA Red

- P4) 24" - CASTING HEIGHT - 6"
- P3) 24" - GRADE RING w/ConBlock-CDA Red - 4"
- P2) 48" - ECC CONE w/ 24" HOLE, w/ConBlock-CDA Red - 30"
- P1) 48" - MH BASE w/ConBlock-CDA Red - 24"
- 1) 48" - MH INVERT CHANNEL - FULL HEIGHT
- 1) JOINT WRAP - 0.065"x6"x50' CONSEAL CS212
- 1) JOINT WRAP PRIMER - CONSEAL CS-75 (1 gal.)
- 1) CASTING - JBS 1155 F/C SANITARY
- 1) 48" - Conseal CS-102 1.00" (Double)
- 2) PSX - 12-08 NYLO
- 5) MH Step ML-10-TDS-NCR - 10"

- 0 lb Structure Notes:
1. PER ASTM C478 SPECIFICATIONS.
 2. CONCRETE = 4,000 PSI AT 28 DAYS.
 3. ADMIXTURE = CONBLOCK CDA RED.
 4. CASTING JBS 1155 "Sanitary" BY ICAST
- 270 lb
 1961 lb
 2911 lb
 1440 lb
 0 lb
 0 lb
 250 lb
 0 lb
 0 lb
 16 lb
 0 lb
- REINFORCING PER ASTM A615 (GRADE 60).
 - CONE (As .12)
 - RISER/WALLS (As .12)
 - FLOOR (As .31) #5 BARS AT 12" C.C.E.W.

Structure Total: 6848 lb

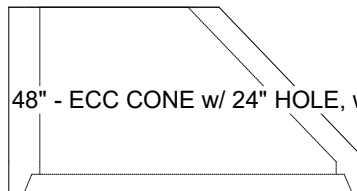
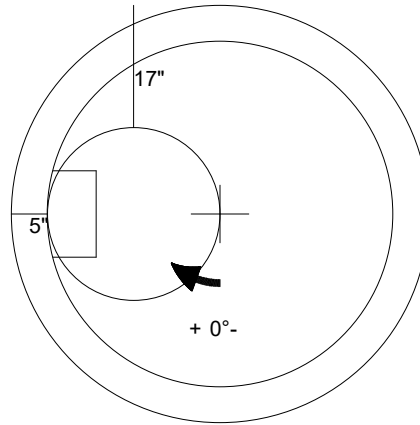

48" - ECC CONE w/ 24" HOLE, w/ConBlock-CDA Red - 30" - (P2)

Coating (Int): Coating (Ext):	Seam Up: Flat Seam Dn: Groove	Wall Thickness: 5"	Height (Ext): 30"	Weight (Net): 1961 lb Volume (Net): 0.5cu.yd
----------------------------------	----------------------------------	--------------------	-------------------	---