

Job Name: 25-2511C Blue Sky Sec. 1  
 Job Location: Clarksville, TN  
 Contractor: Byard Construction, LLC

Plant: Beaver Dam, KY  
 10/21/2025 1:50:26 PM

Tech: J. Coppage  
 PC: Andrew Chamber



**Structure ID: SSMH-A1**

**P1 MH048BA30CDARED**

**MH BASE w/ConBlock-CDA Red**

- P4) 24" - CASTING HEIGHT - 6"
- P3) 48" - ECC CONE w/ 24" HOLE, w/ConBlock-CDA Red - 42"
- P2) 48" - MH RISER w/ConBlock-CDA Red - 48"
- P1) 48" - MH BASE w/ConBlock-CDA Red - 30"
- 1) 48" - MH INVERT CHANNEL - FULL HEIGHT
- 1) JOINT WRAP - 0.065"x6"x50' CONSEAL CS212
- 1) JOINT WRAP PRIMER - CONSEAL CS-75 (1 gal.)
- 1) CASTING - JBS 1155 F/C SANITARY
- 2) 48" - Conseal CS-102 1.00" (Double)
- 3) PSX - 12-08 NYLO
- 10) MH Step ML-10-TDS-NCR - 10"

- Structure Notes:**
1. PER ASTM C478 SPECIFICATIONS.
  2. CONCRETE = 4,000 PSI AT 28 DAYS.
  3. ADMIXTURE = CONBLOCK CDA RED.
  4. CASTING JBS 1155 "Sanitary" BY ICAST
- REINFORCING PER ASTM A615 (GRADE 60).
- CONE (As .12)
  - RISER/WALLS (As .12)
  - FLOOR (As .31) #5 BARS AT 12" C.C.E.W.

Structure Total: 11466 lb

Rim: 501.67' Rim to Invert: 10.41' Slack: 0.92" Sump: 2" Step Position: 292.5°

Position	Elev	Angle	Ext. (cw)	Pipe	Pipe OD	Connector	Hole	Horz Size	Up ( )	Offset
Invert 1	491.26'	0°	0"	8" PVC SDR26	8.5"	PSX 12-08 NYLO	12"	12.129"	0"	0"
Invert 2	491.36'	93°	47.072"	8" PVC SDR26	8.5"	PSX 12-08 NYLO	12"	12.129"	1.2"	0"
Invert 3	491.36'	225°	113.883"	8" PVC SDR26	8.5"	PSX 12-08 NYLO	12"	12.129"	1.2"	0"
Invert 4										
Invert 5										
Invert 6										
Invert 7										
Invert 8										

RIGHT-SIDE UP VIEW (int. dimensions)

UPSIDE-DOWN VIEW (int. dimensions)

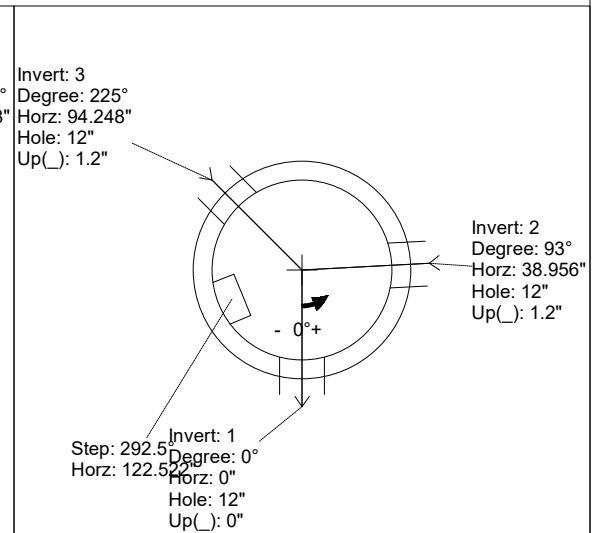
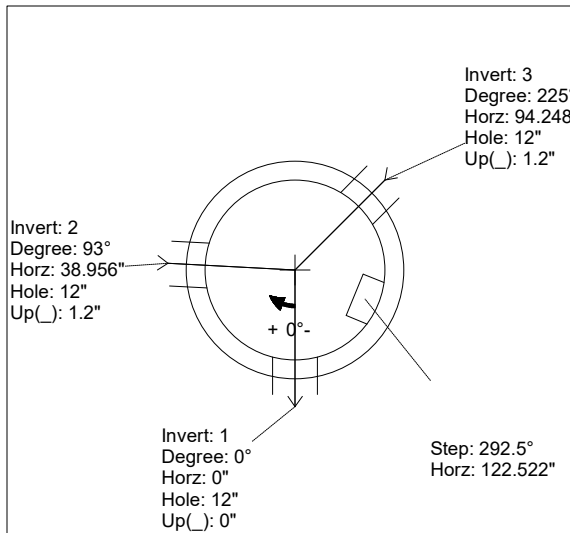
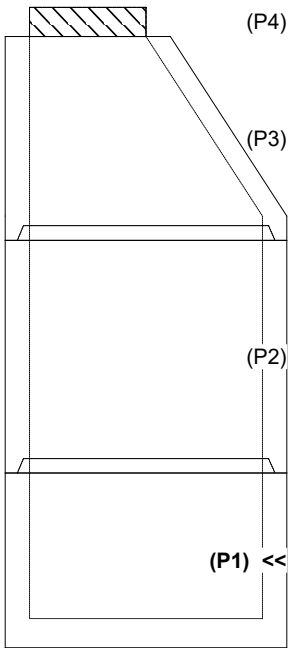

INSIDE WALL DIMENSIONS

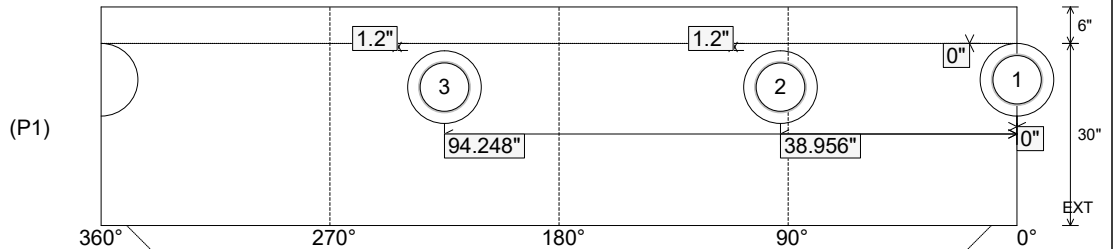

Coating (Int):  
 Coating (Ext):

Seam Up: Tongue  
 Seam Dn: n/a

Wall Thickness: 5"  
 Floor Height: 6"

Height (Int): 30"  
 Height (Ext): 36"

Weight (Net): 3282 lb  
 Volume (Net): 0.84cu.yd

Job Name: 25-2511C Blue Sky Sec. 1  
 Job Location: Clarksville, TN  
 Contractor: Byard Construction, LLC

Plant: Beaver Dam, KY  
 10/21/2025 1:50:26 PM

Tech: J. Coppage  
 PC: Andrew Chamber



**Structure ID: SSMH-A1**

**P1 MH048BA30CDARED**

**MH BASE w/ConBlock-CDA Red**

- P4) 24" - CASTING HEIGHT - 6"
- P3) 48" - ECC CONE w/ 24" HOLE, w/ConBlock-CDA Red - 42"
- P2) 48" - MH RISER w/ConBlock-CDA Red - 48"
- P1) 48" - MH BASE w/ConBlock-CDA Red - 30"
- 1) 48" - MH INVERT CHANNEL - FULL HEIGHT
- 1) JOINT WRAP - 0.065"x6"x50' CONSEAL CS212
- 1) JOINT WRAP PRIMER - CONSEAL CS-75 (1 gal.)
- 1) CASTING - JBS 1155 F/C SANITARY
- 2) 48" - Conseal CS-102 1.00" (Double)
- 3) PSX - 12-08 NYLO
- 10) MH Step ML-10-TDS-NCR - 10"

- Structure Notes:**
1. PER ASTM C478 SPECIFICATIONS.
  2. CONCRETE = 4,000 PSI AT 28 DAYS.
  3. ADMIXTURE = CONBLOCK CDA RED.
  4. CASTING JBS 1155 "Sanitary" BY ICAST
- REINFORCING PER ASTM A615 (GRADE 60).
- CONE (As .12)
  - RISER/WALLS (As .12)
  - FLOOR (As .31) #5 BARS AT 12" C.C.E.W.

Structure Total: 11466 lb

**INVERT CHANNEL DRAWING  
 FULL HEIGHT INVERT**

Rim: 501.67' Rim to Invert: 10.41' Slack: 0.92" Sump: 2" Step Position: 292.5°

Position	Elev	Angle	Ext. (cw)	Pipe	Pipe OD	Connector	Hole	Horz Size	Up ( )	Offset
Invert 1	491.26'	0°	0"	8" PVC SDR26	8.5"	PSX 12-08 NYLO	12"	12.129"	0"	0"
Invert 2	491.36'	93°	47.072"	8" PVC SDR26	8.5"	PSX 12-08 NYLO	12"	12.129"	1.2"	0"
Invert 3	491.36'	225°	113.883"	8" PVC SDR26	8.5"	PSX 12-08 NYLO	12"	12.129"	1.2"	0"
Invert 4										
Invert 5										
Invert 6										
Invert 7										
Invert 8										

RIGHT-SIDE UP VIEW (int. dimensions)

UPSIDE-DOWN VIEW (int. dimensions)

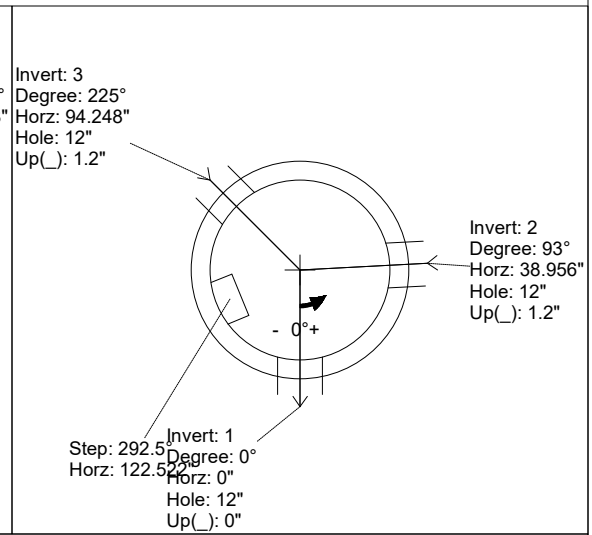
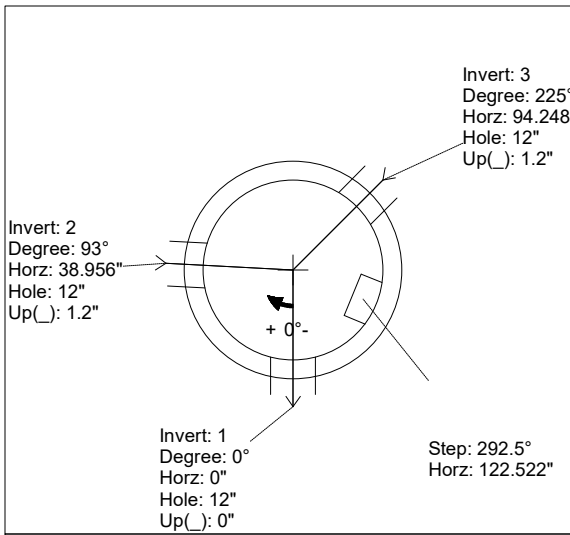
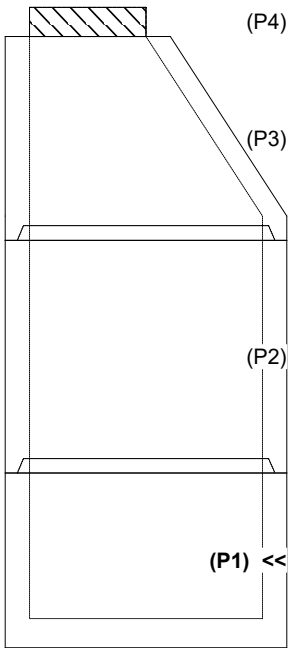

INSIDE WALL DIMENSIONS

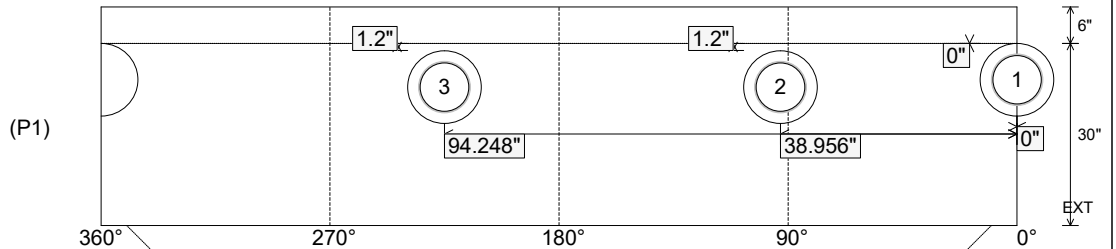

Coating (Int):  
 Coating (Ext):

Seam Up: Tongue  
 Seam Dn: n/a

Wall Thickness: 5"  
 Floor Height: 6"

Height (Int): 30"  
 Height (Ext): 36"

Weight (Net): 3282 lb  
 Volume (Net): 0.84cu.yd