

Job Name: 25-2468 Kerrick Elementary
 Job Location: Louisville, KY
 Contractor: KY Earthworks

Plant: Beaver Dam

Tech: J. Horsley

11/14/2025 2:17:13 PM

PC: J. Jarvis



Structure ID: ST 17-CB

P1 BX1836-08BAVF

BOX BASE 8inW, 8inF, Variable Ht F/n

- P2) 18" x 36" - CASTING HEIGHT - 5.5"
- P1) 18" x 36" - BOX BASE 8inW, 8inF, Variable Ht F/n - 26"
- 1) 18" x 36" - Conseal CS-102 1.00"
- 1) Hole - 24
- 2) Hole - 16

0 lb
 3112 lb
 0 lb
 0 lb
 0 lb
 0 lb

 Structure Total: 3112 lb

Structure Notes:
 1. PER LOUISVILLE MSD/ ASTM C913 SPECIFICATIONS.
 2. CONCRETE = 4,000 PSI AT 28 DAYS.
 3. CASTING BY OTHERS (HOE 580-A F/G)

REINFORCING PER ASTM A615 (GRADE 60).
 - WALLS (As .31) #5 BARS AT 12" C.C.E.W.
 - FLOOR (As .31) #5 BARS AT 12" C.C.E.W.

Rim: 448.4' Rim to Invert: 2.6' Slack: -0.3" Sump: 0" Step Position:

Position	Elev	Angle	Ext. (cw)	Pipe	Pipe OD	Connector	Hole	Horz Size	Up ()	Offset
Invert 1	445.8'	180°	17"	18" HDPE	21.2"	Hole 24	24"	21"	-1.625"	0"
Invert 2	445.8'	0°	17"	12" HDPE	14.5"	Hole 16	16"	16"	-1.25"	0"
Invert 3	445.8'	60°	22"	12" HDPE	14.5"	Hole 16	16"	18.475"	-1.25"	5"
Invert 4										
Invert 5										
Invert 6										
Invert 7										
Invert 8										

RIGHT-SIDE UP VIEW (int. dimensions)

UPSIDE-DOWN VIEW (int. dimenions)

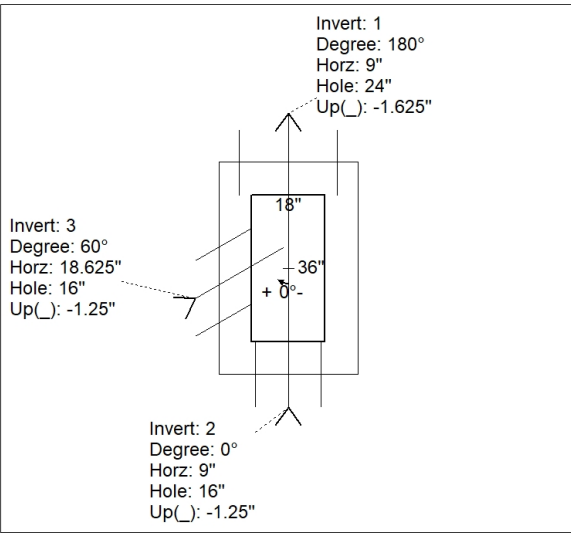

1ST POUR (FLOOR) = 1,186 LBS
 2ND POUR (WALLS) = 1,926 LBS

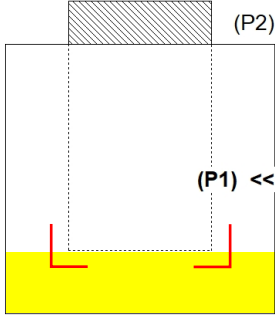

INSIDE WALL DIMENSIONS

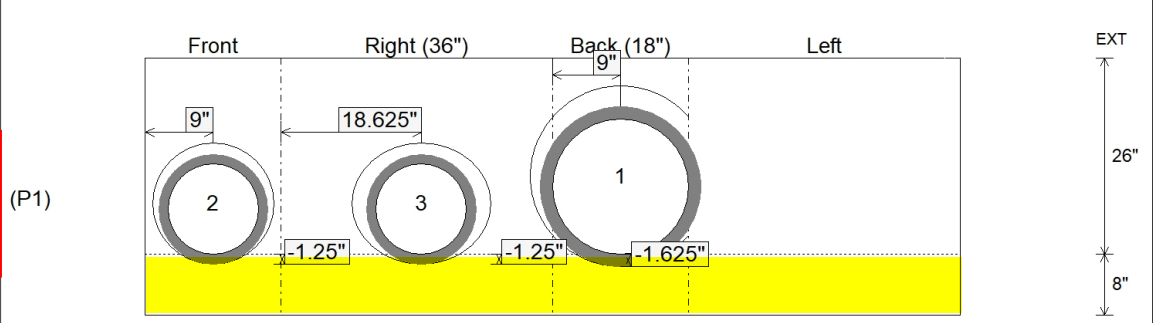

1ST POUR (FLOOR)
 STUB #5 BARS OUT TOP OF FLOOR, SPA AT 12" C/C FOR CONNECTING WALLS

Coating (Int): Coating (Ext):	Seam Up: Flat Seam Dn: n/a	Wall Thickness: 8" Floor Height: 8"	Height (Int): 26" Height (Ext): 34"	Weight (Net): 3112 lb Volume (Net): 0.8cu.yd
----------------------------------	-------------------------------	--	--	---

Job Name: 25-2468 Kerrick Elementary
 Job Location: Louisville, KY
 Contractor: KY Earthworks

Plant: Beaver Dam

Tech: J. Horsley

11/14/2025 2:17:13 PM

PC: J. Jarvis



Structure ID: ST 17-CB

P1A BX1836-08BAVF

BOX BASE 8inW, 8inF, Variable Ht F/n

- P2) 18" x 36" - CASTING HEIGHT - 5.5"
- P1) 18" x 36" - BOX BASE 8inW, 8inF, Variable Ht F/n - 26"
- 1) 18" x 36" - Conseal CS-102 1.00"
- 1) Hole - 24
- 2) Hole - 16

0 lb
 3112 lb
 0 lb
 0 lb
 0 lb
 Structure Total: 3112 lb

Structure Notes:

1. PER LOUISVILLE MSD/ ASTM C913 SPECIFICATIONS.
2. CONCRETE = 4,000 PSI AT 28 DAYS.
3. CASTING BY OTHERS (HOE 580-A F/G)

REINFORCING PER ASTM A615 (GRADE 60).

- WALLS (As .31) #5 BARS AT 12" C.C.E.W.
- FLOOR (As .31) #5 BARS AT 12" C.C.E.W.

Rim: 448.4' Rim to Invert: 2.6' Slack: -0.3" Sump: 0" Step Position:

Position	Elev	Angle	Ext. (cw)	Pipe	Pipe OD	Connector	Hole	Horz Size	Up ()	Offset
Invert 1	445.8'	180°	17"	18" HDPE	21.2"	Hole 24	24"	21"	-1.625"	0"
Invert 2	445.8'	0°	17"	12" HDPE	14.5"	Hole 16	16"	16"	-1.25"	0"
Invert 3	445.8'	60°	22"	12" HDPE	14.5"	Hole 16	16"	18.475"	-1.25"	5"
Invert 4										
Invert 5										
Invert 6										
Invert 7										
Invert 8										

RIGHT-SIDE UP VIEW (int. dimensions)

UPSIDE-DOWN VIEW (int. dimenions)

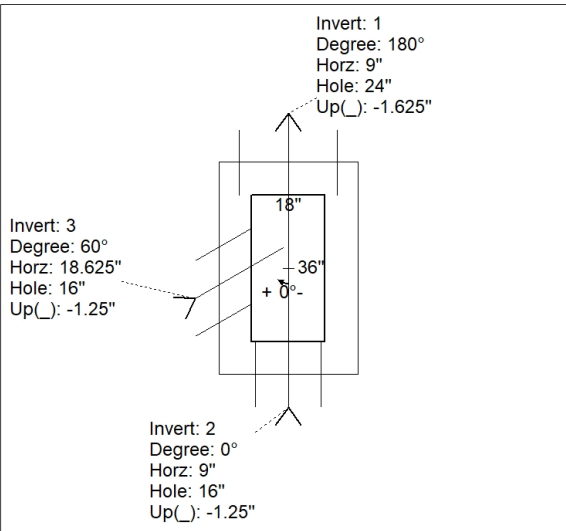

**1ST POUR (FLOOR) = 1,186 LBS
 2ND POUR (WALLS) = 1,926 LBS**

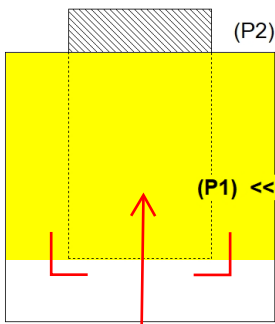

INSIDE WALL DIMENSIONS

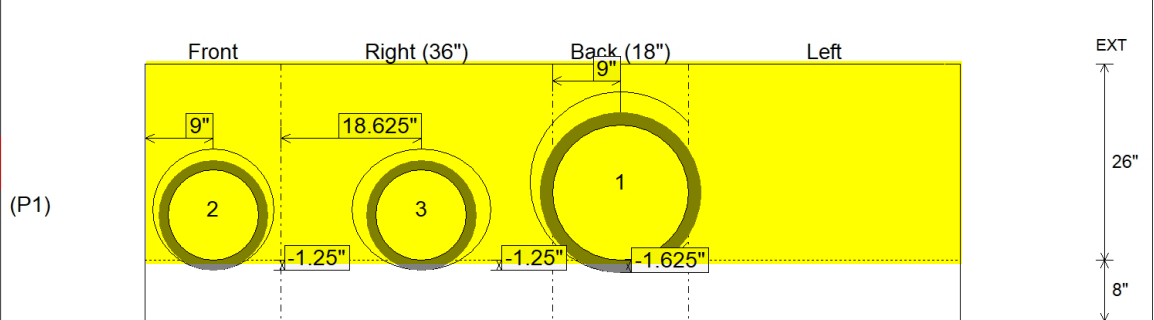

2ND POUR (WALLS)

Coating (Int):
 Coating (Ext):

Seam Up: Flat
 Seam Dn: n/a

Wall Thickness: 8"
 Floor Height: 8"

Height (Int): 26"
 Height (Ext): 34"

Weight (Net): 3112 lb
 Volume (Net): 0.8cu.yd