

Job Name: 25-2468 Kerrick Elementary  
 Job Location: Louisville, KY  
 Contractor: KY Earthworks

Plant: Beaver Dam

Tech: J. Horsley

11/20/2025 4:06:47 PM

PC: J. Jarvis



**Structure ID: DS2**

**P1 MH048BAVF**

**MH BASE Custom Ht F/n**

- P3) 24" - CASTING HEIGHT - 7"
- P2) 48" - MH FLAT TOP SPEC. HT. (6") F/F - 6"
- P1) 48" - MH BASE Custom Ht F/n - 34"
- 1) 60" x 12" - WEIR WALL 6" THK - SECONDARY POUR
- 1) 48" - SGL 1"x14.5' Butyl (2x)
- 2) Hole - 30
- 2) Hole - 16

0 lb  
 1102 lb  
 2859 lb  
 363 lb  
 0 lb  
 0 lb  
 0 lb  
 -----  
 Structure Total: 4324 lb

**Structure Notes:**  
 1. PER LOUISVILLE MSD/ ASTM C478 SPECIFICATIONS.  
 2. CONCRETE = 4,000 PSI AT 28 DAYS.  
 3. CASTING BY OTHERS (HOE MC-420 F/C).  
 4. WEIR WALL (6" WD x 11.5" TALL) TOP EL. 445.55'  
 REINFORCING PER ASTM A615 (GRADE 60).  
 - TOP SLAB (As .62) #5 BARS AT 6" C.C.E.W..  
 - RISER/WALLS (As .12)  
 - FLOOR (As .31) #5 BARS AT 12" C.C.E.W.

Rim: 448.4' Rim to Invert: 3.8' Slack: 0.5' Sump: 1.9' Step Position:

Position	Elev	Angle	Ext. (cw)	Pipe	Pipe OD	Connector	Hole	Horz Size	Up ( )	Offset
Invert 1	444.6'	0°	0"	24" HDPE	27.8"	Hole 30	30"	32.406"	0"	0"
Invert 2	444.6'	180°	91.125"	24" HDPE	27.8"	Hole 30	30"	32.406"	0"	0"
Invert 3	444.6'	270°	122"	10" HDPE	11.4"	Hole 16	16"	21.767"	1.25"	-14"
Invert 4	444.6'	270°	151.25"	10" HDPE	11.4"	Hole 16	16"	21.767"	1.25"	14"
Invert 5										
Invert 6										
Invert 7										
Invert 8										

RIGHT-SIDE UP VIEW (int. dimensions)

UPSIDE-DOWN VIEW (int. dimensions)

**SECONDARY POUR REQ'D  
 SEE SHEET P1A**

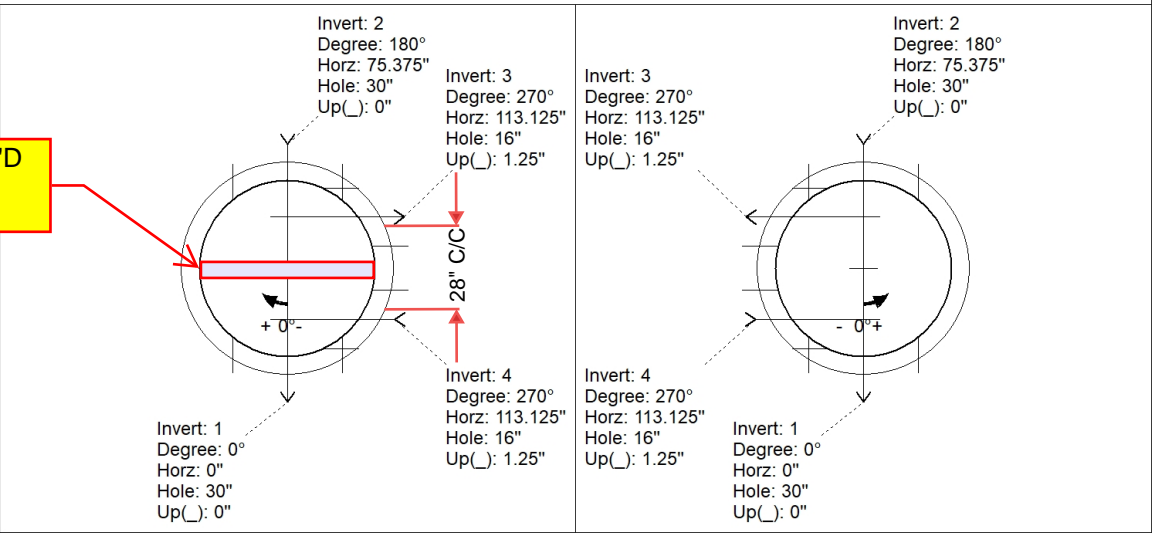
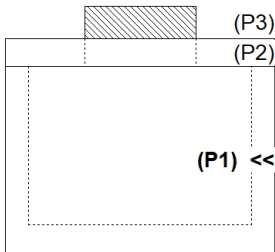

INSIDE WALL DIMENSIONS

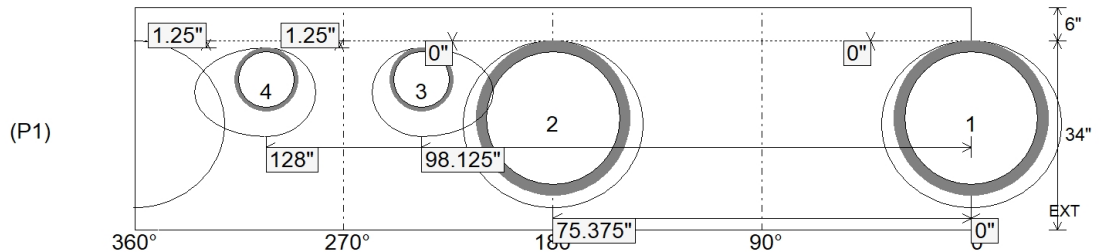

Coating (Int):  
 Coating (Ext):

Seam Up: Flat  
 Seam Dn: n/a

Wall Thickness: 5"  
 Floor Height: 6"

Height (Int): 34"  
 Height (Ext): 40"

Weight (Net): 2859 lb  
 Volume (Net): 0.73cu.yd

Job Name: 25-2468 Kerrick Elementary  
 Job Location: Louisville, KY  
 Contractor: KY Earthworks

Plant: Beaver Dam

Tech: J. Horsley

11/20/2025 4:06:47 PM

PC: J. Jarvis



**Structure ID: DS2**

**P1A MH048BAVF**

**MH BASE Custom Ht F/n**

- P3) 24" - CASTING HEIGHT - 7"
- P2) 48" - MH FLAT TOP SPEC. HT. (6") F/F - 6"
- P1) 48" - MH BASE Custom Ht F/n - 34"
- 1) 60" x 12" - WEIR WALL 6" THK - SECONDARY POUR
- 1) 48" - SGL 1"x14.5' Butyl (2x)
- 2) Hole - 30
- 2) Hole - 16

0 lb  
 1102 lb  
 2859 lb  
 363 lb  
 0 lb  
 0 lb  
 0 lb  
 0 lb

Structure Total: 4324 lb

- Structure Notes:**
1. PER LOUISVILLE MSD/ ASTM C478 SPECIFICATIONS.
  2. CONCRETE = 4,000 PSI AT 28 DAYS.
  3. CASTING BY OTHERS (HOE MC-420 F/C).
  4. WEIR WALL (6" WD x 11.5" TALL) TOP EL. 445.55'

REINFORCING PER ASTM A615 (GRADE 60).  
 - TOP SLAB (As .62) #5 BARS AT 6" C.C.E.W..  
 - RISER/WALLS (As .12)  
 - FLOOR (As .31) #5 BARS AT 12" C.C.E.W.

Rim: 448.4' Rim to Invert: 3.8' Slack: 0.5' Sump: 1.9' Step Position:

Position	Elev	Angle	Ext. (cw)	Pipe	Pipe OD	Connector	Hole	Horz Size	Up ( )	Offset
Invert 1	444.6'	0°	0"	24" HDPE	27.8"	Hole 30	30"	32.406"	0"	0"
Invert 2	444.6'	180°	91.125"	24" HDPE	27.8"	Hole 30	30"	32.406"	0"	0"
Invert 3	444.6'	270°	122"	10" HDPE	11.4"	Hole 16	16"	21.767"	1.25"	-14"
Invert 4	444.6'	270°	151.25"	10" HDPE	11.4"	Hole 16	16"	21.767"	1.25"	14"
Invert 5										
Invert 6										
Invert 7										
Invert 8										

RIGHT-SIDE UP VIEW (int. dimensions)

UPSIDE-DOWN VIEW (int. dimensions)

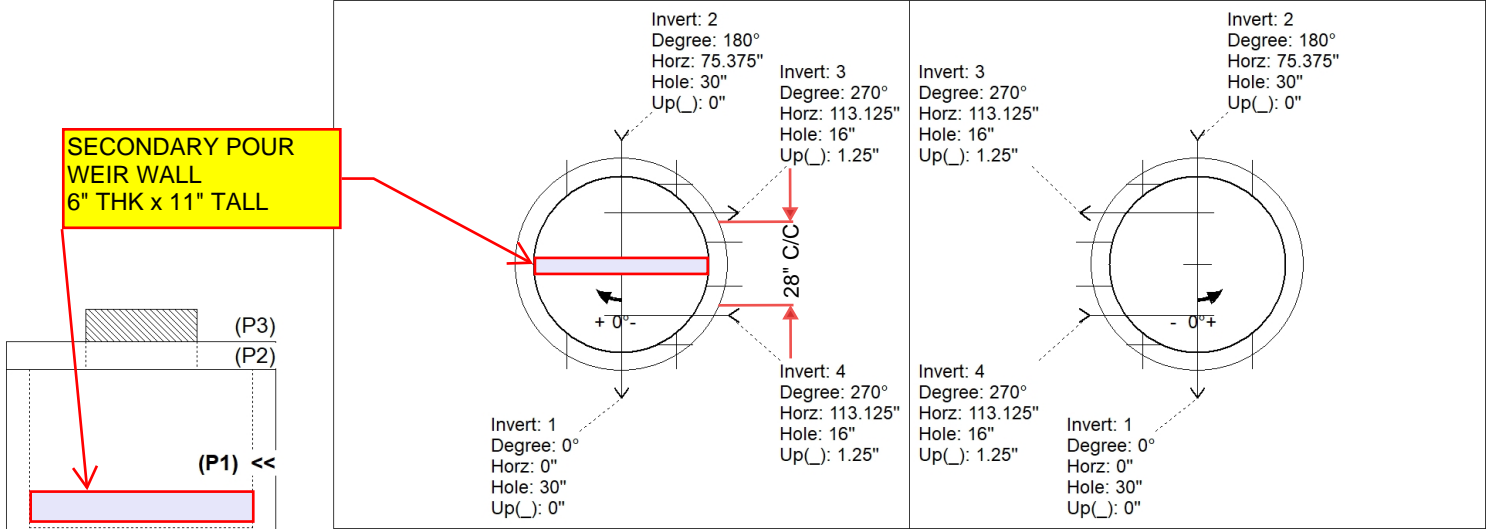

INSIDE WALL DIMENSIONS

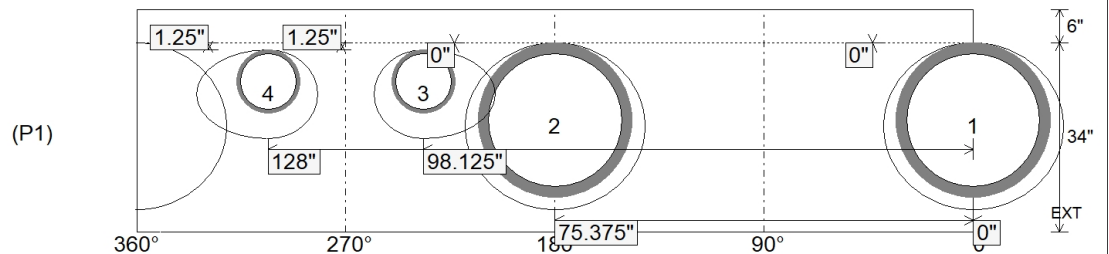

Coating (Int):  
 Coating (Ext):

Seam Up: Flat  
 Seam Dn: n/a

Wall Thickness: 5"  
 Floor Height: 6"

Height (Int): 34"  
 Height (Ext): 40"

Weight (Net): 2859 lb  
 Volume (Net): 0.73cu.yd