

Job Name: 25-2468 Kerrick Elementary  
 Job Location: Louisville, KY  
 Contractor: KY Earthworks

Plant: Beaver Dam  
 11/14/2025 3:32:49 PM

Tech: J. Horsley  
 PC: J. Jarvis



**Structure ID: DS1**  
**P1 MH060BAVF**

**MH BASE Custom Ht T/n**

P3) 24" - CASTING HEIGHT - 7"	0 lb
P2) 60" - MH FLAT TOP w/ 24" ECC Hole F/G - 13"	2869 lb
P1) 60" - MH BASE Custom Ht T/n - 34"	5586 lb
1) 48" x 12" - WEIR WALL 6" THK - SECONDARY POUR	290 lb
1) 60" - SGL 1"x14.5' Butyl (2x)	0 lb
2) Hole - 24	0 lb
2) Hole - 16	0 lb
<b>Structure Total:</b>	<b>8745 lb</b>

**Structure Notes:**  
 1. PER LOUISVILLE MSD/ ASTM C478 SPECIFICATIONS.  
 2. CONCRETE = 4,000 PSI AT 28 DAYS.  
 3. CASTING BY OTHERS (HOE MC-420 F/C).  
 4. WEIR WALL (6" WD x 11.5" TALL) TOP EL. 444.80'

REINFORCING PER ASTM A615 (GRADE 60).  
 - TOP SLAB (As .62) #5 BARS AT 6" C.C.E.W..  
 - RISER/WALLS (As 8  
 - FLOOR (As .31) #5 BARS AT 12" C.C.E.W.

Rim: 448.4' Rim to Invert: 4.55' Slack: 0.6" Sump: 0" Step Position:

Position	Elev	Angle	Ext. (cw)	Pipe	Pipe OD	Connector	Hole	Horz Size	Up ( )	Offset
Invert 1	443.85'	0°	0"	18" HDPE	21.2"	Hole 24	24"	24.691"	-1.625"	0"
Invert 2	443.85'	180°	113.125"	18" HDPE	21.2"	Hole 24	24"	24.691"	-1.625"	0"
Invert 3	443.85'	270°	155.25"	10" HDPE	11.4"	Hole 16	16"	18.656"	-0.75"	-14"
Invert 4	443.85'	270°	184"	10" HDPE	11.4"	Hole 16	16"	18.656"	-0.75"	14"
Invert 5										
Invert 6										
Invert 7										
Invert 8										

RIGHT-SIDE UP VIEW (int. dimensions)

UPSIDE-DOWN VIEW (int. dimensions)

**SECONDARY POUR REQ'D  
 SEE SHEET P1A**

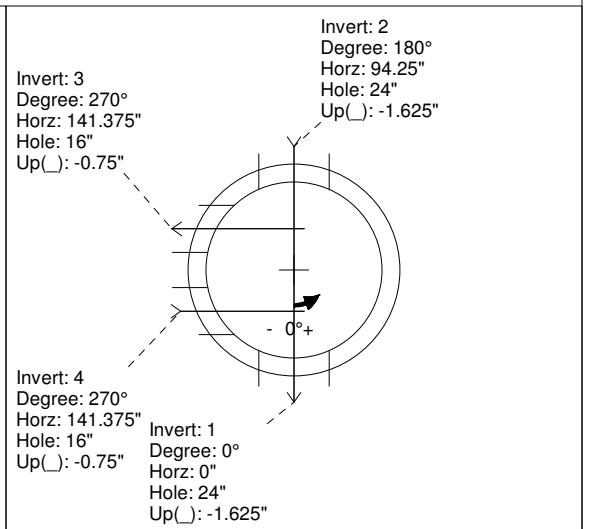
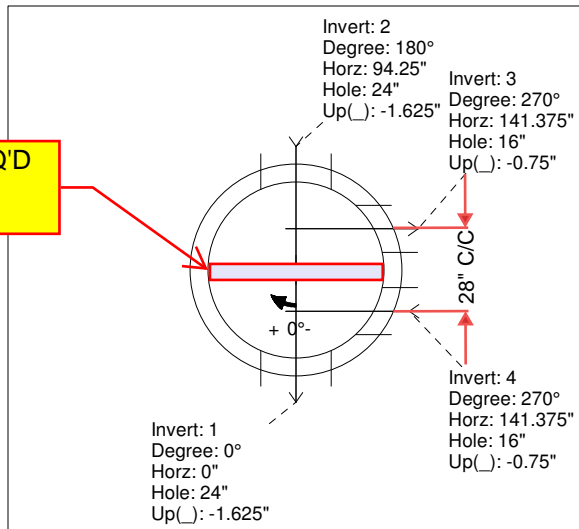
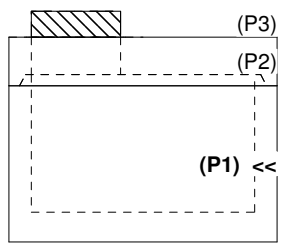

INSIDE WALL DIMENSIONS

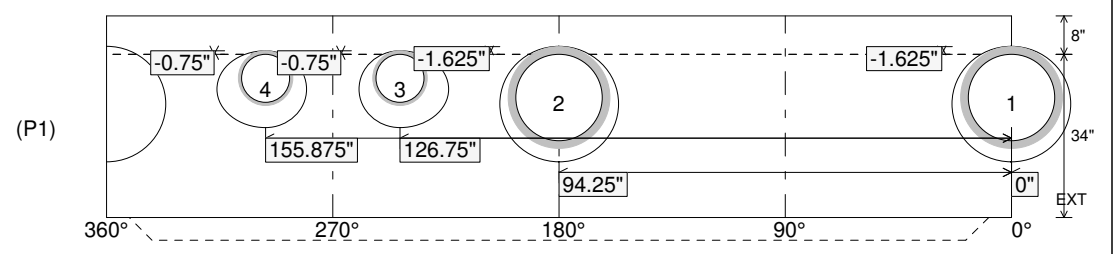

Coating (Int): Coating (Ext):	Seam Up: Tongue Seam Dn: n/a	Wall Thickness: 6" Floor Height: 8"	Height (Int): 34" Height (Ext): 42"	Weight (Net): 5586 lb Volume (Net): 1.43cu.yd
----------------------------------	---------------------------------	--	--	--

Job Name: 25-2468 Kerrick Elementary  
 Job Location: Louisville, KY  
 Contractor: KY Earthworks

Plant: Beaver Dam  
 11/14/2025 3:34:33 PM

Tech: J. Horsley  
 PC: J. Jarvis



**Structure ID: DS1**

**P1A MH060BAVF**

**MH BASE Custom Ht T/n**

- P3) 24" - CASTING HEIGHT - 7"
- P2) 60" - MH FLAT TOP w/ 24" ECC Hole F/G - 13"
- P1) 60" - MH BASE Custom Ht T/n - 34"
- 1) 48" x 12" - WEIR WALL 6" THK - SECONDARY POUR
- 1) 60" - SGL 1"x14.5' Butyl (2x)
- 2) Hole - 24
- 2) Hole - 16

**Structure Notes:**  
 1. PER LOUISVILLE MSD/ ASTM C478 SPECIFICATIONS.  
 2. CONCRETE = 4,000 PSI AT 28 DAYS.  
 3. CASTING BY OTHERS (HOE MC-420 F/C).  
 4. WEIR WALL (6" WD x 11.5" TALL) TOP EL. 444.80'

REINFORCING PER ASTM A615 (GRADE 60).  
 - TOP SLAB (As .62) #5 BARS AT 6" C.C.E.W..  
 - RISER/WALLS (As 8)  
 - FLOOR (As .31) #5 BARS AT 12" C.C.E.W.

0 lb  
 2869 lb  
 5586 lb  
 290 lb  
 0 lb  
 0 lb  
 0 lb  
 -----  
 Structure Total: 8745 lb

Rim: 448.4' Rim to Invert: 4.55' Slack: 0.6" Sump: 0" Step Position:

Position	Elev	Angle	Ext. (cw)	Pipe	Pipe OD	Connector	Hole	Horz Size	Up ( )	Offset
Invert 1	443.85'	0°	0"	18" HDPE	21.2"	Hole 24	24"	24.691"	-1.625"	0"
Invert 2	443.85'	180°	113.125"	18" HDPE	21.2"	Hole 24	24"	24.691"	-1.625"	0"
Invert 3	443.85'	270°	155.25"	10" HDPE	11.4"	Hole 16	16"	18.656"	-0.75"	-14"
Invert 4	443.85'	270°	184"	10" HDPE	11.4"	Hole 16	16"	18.656"	-0.75"	14"
Invert 5										
Invert 6										
Invert 7										
Invert 8										

**RIGHT-SIDE UP VIEW (int. dimensions) - - SECONDARY POUR**

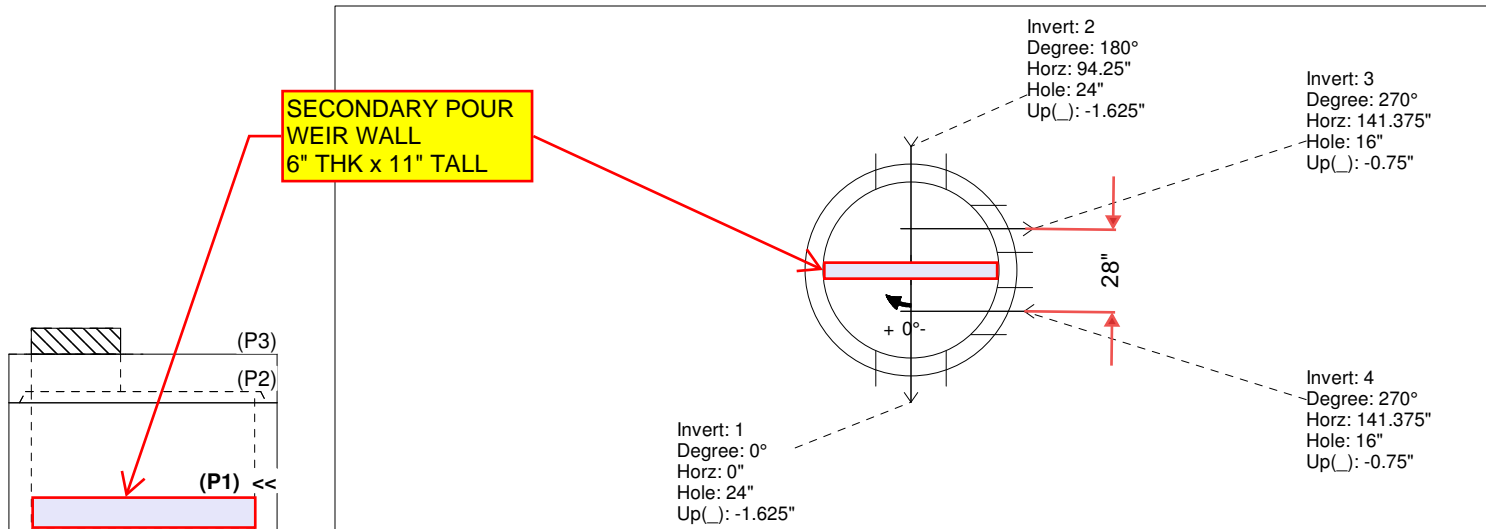

**INSIDE WALL DIMENSIONS**

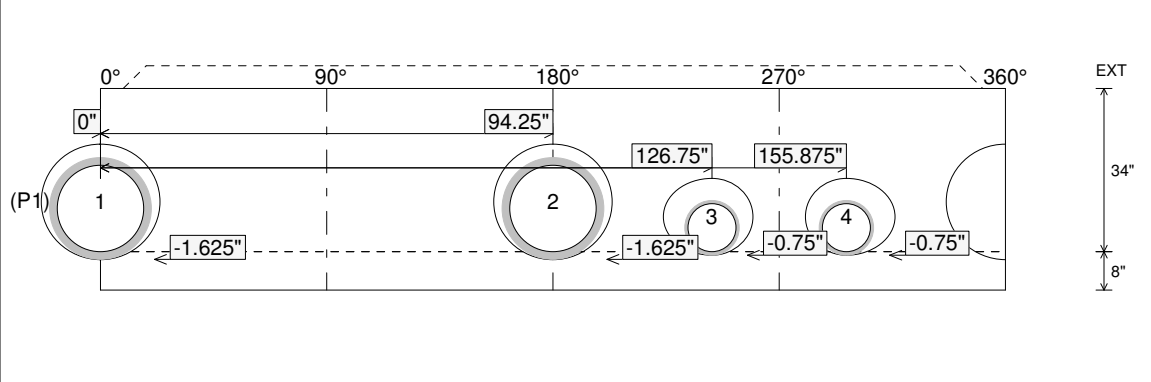

Coating (Int): Coating (Ext):	Seam Up: Tongue Seam Dn: n/a	Wall Thickness: 6" Floor Height: 8"	Height (Int): 34" Height (Ext): 42"	Weight (Net): 5586 lb Volume (Net): 1.43cu.yd
----------------------------------	---------------------------------	--	--	--