

Job Name: 25-2418 Marvin's Lift Station  
 Job Location: Radcliff, KY 40160  
 Contractor: Ferguson Waterworks #1491

Plant: Beaver Dam, KY  
 12/23/2025 7:45:46 AM

Tech: C. Russ  
 PC: C. Goff



**Structure ID: 1**

**P4 MH048CN24-SCDARED**

**ECC CONE w/ 24" HOLE NO STEPS, w/ConBlock-CDA Red F/G**

|   |          |
|---|----------|
| P6) 24" - CASTING HEIGHT - 7"   | 0 lb     |
| P5) 24" - GRADE RING w/ConBlock-CDA Red F/F - 4"                      | 270 lb   |
| P4) 48" - ECC CONE w/ 24" HOLE NO STEPS, w/ConBlock-CDA Red F/G - 24" | 1550 lb  |
| P3) 48" - MH RISER w/ConBlock-CDA Red NO STEPS T/G - 60"              | 4192 lb  |
| P2) 48" - MH RISER w/ConBlock-CDA Red NO STEPS T/G - 60"              | 4192 lb  |
| P1) 48" - MH BASE w/ConBlock-CDA Red T/n - 42"                        | 4121 lb  |
| 1) JOINT WRAP - 0.065"x6"x50" CONSEAL CS212                           | 0 lb     |
| 1) JOINT WRAP PRIMER - CONSEAL CS-75 (1 gal.)                         | 0 lb     |
| 1) 48" - MH INVERT CHANNEL w/ConBlock-CDA Red - FULL HEIGHT           | 1440 lb  |
| 1) ADMIXTURE CONBLOCK CDA RED   | 0 lb     |
| 1) Chimney Seal - Cretex Chimney Seal                                 | 10 lb    |
| 3) 48" - Hamilton Kent MH Gasket                                      | 0 lb     |
| 3) PSX - 12-08 NYLO   | 24 lb    |
| Structure Total:  | 15798 lb |

- Structure Notes:
1. PER ASTM C-478 SPECIFICATIONS
  2. CONCRETE: 4,000 PSI AT 28 DAYS
  3. REINFORCEMENT: PER ASTM A615
  4. INVERT CHANNEL REQUIRED
  5. CONBLOCK CDA RED ADMIXTURE REQUIRED
  6. NO STEPS
  7. CASTING BY OTHERS (HOE MC-315 FRAME & COVER "SANITARY")
  8. CHIMEY SEAL BY ICAST

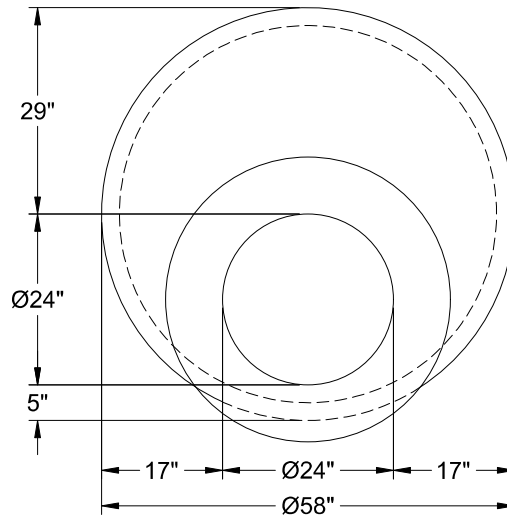

48" - ECC CONE w/ 24" HOLE NO STEPS, w/ConBlock-CDA Red F/G - 24" - (P4)

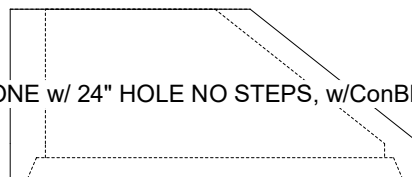

|                                  |                                  |                    |                   |  |
|----------------------------------|----------------------------------|--------------------|-------------------|--|
| Coating (Int):<br>Coating (Ext): | Seam Up: Flat<br>Seam Dn: Groove | Wall Thickness: 5" | Height (Ext): 24" | Weight (Net): 1550 lb<br>Volume (Net): 0.33cu.yd |
|----------------------------------|----------------------------------|--------------------|-------------------|--|