

Job Name: 25-2310 GOOSE CREEK SUBDIVISION  
 Job Location: Hartsville, TN  
 Contractor: Hayes Pipe Supply

Plant: Beaver Dam  
 2/4/2026 12:36:19 PM

Tech: C.Russ  
 PC: A.Chambers



**Structure ID: SSMH 2**

**P1 MH048BA30CDARED**

**MH BASE w/ConBlock-CDA Red T/n**

- P4) 24" - CASTING HEIGHT - 7.50" 0 lb
- P3) 48" - ECC CONE w/ 24" HOLE, w/ConBlock-CDA Red F/G - 30" 1961 lb
- P2) 48" - MH RISER w/ConBlock-CDA Red T/G - 36" 2515 lb
- P1) 48" - MH BASE w/ConBlock-CDA Red T/n - 30" 3330 lb
- 1) JOINT WRAP - 0.065"x6"x50' CONSEAL CS212 0 lb
- 1) JOINT WRAP PRIMER - CONSEAL CS-75 (1 gal.) 0 lb
- 1) ADMIXTURE CONBLOCK CDA RED 0 lb
- 1) 48" - MH INVERT CHANNEL w/ConBlock-CDA Red - FULL HEIGHT 1440 lb
- 2) 48" - Conseal CS-102 1.00" (Double) 0 lb
- 2) PSX - 12-08 NYLO 16 lb
- 8) MH Step ML-10-TDS-NCR - 10" 0 lb

Structure Total: 9263 lb

**Structure Notes:**  
 1. PER ASTM C478 SPECIFICATIONS.  
 2. CONCRETE = 4,000 PSI AT 28 DAYS.  
 3. ADMIXTURE = CONBLOCK-CDA RED.  
 4. CASTING BY OTHERS (JBS 1150 F/C).

REINFORCING PER ASTM A615 (GRADE 60).  
 - CONE (As .12)  
 - RISER (As .12)  
 - FLOOR (As .31) #5 BARS AT 12" C.C.E.W.

Rim: 476' Rim to Invert: 8.47' Slack: 0.14" Sump: 2" Step Position: 270°

| Position | Elev    | Angle | Ext. (cw) | Pipe         | Pipe OD | Connector      | Hole | Horz Size | Up ( ) | Offset |
|----------|---------|-------|-----------|--------------|---------|----------------|------|-----------|--------|--------|
| Invert 1 | 467.53' | 0°    | 0"        | 8" PVC SDR26 | 8.5"    | PSX 12-08 NYLO | 12"  | 12.129"   | 0"     | 0"     |
| Invert 2 | 467.63' | 178°  | 90.125"   | 8" PVC SDR26 | 8.5"    | PSX 12-08 NYLO | 12"  | 12.129"   | 1.25"  | 0"     |
| Invert 3 |         |       |           |              |         |                |      |           |        |        |
| Invert 4 |         |       |           |              |         |                |      |           |        |        |
| Invert 5 |         |       |           |              |         |                |      |           |        |        |
| Invert 6 |         |       |           |              |         |                |      |           |        |        |
| Invert 7 |         |       |           |              |         |                |      |           |        |        |
| Invert 8 |         |       |           |              |         |                |      |           |        |        |

RIGHT-SIDE UP VIEW (int. dimensions)

UPSIDE-DOWN VIEW (int. dimensions)

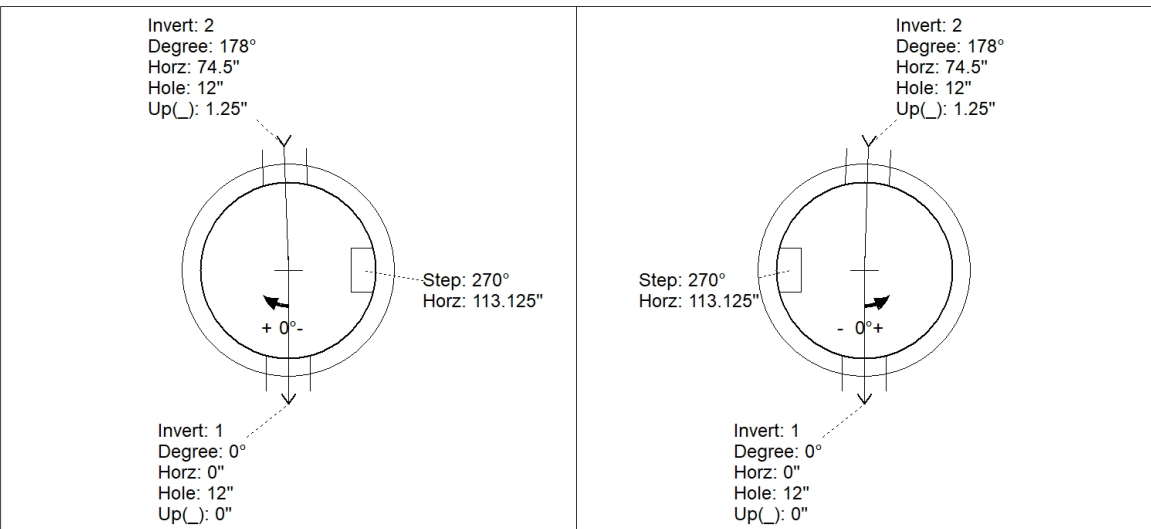

INSIDE WALL DIMENSIONS

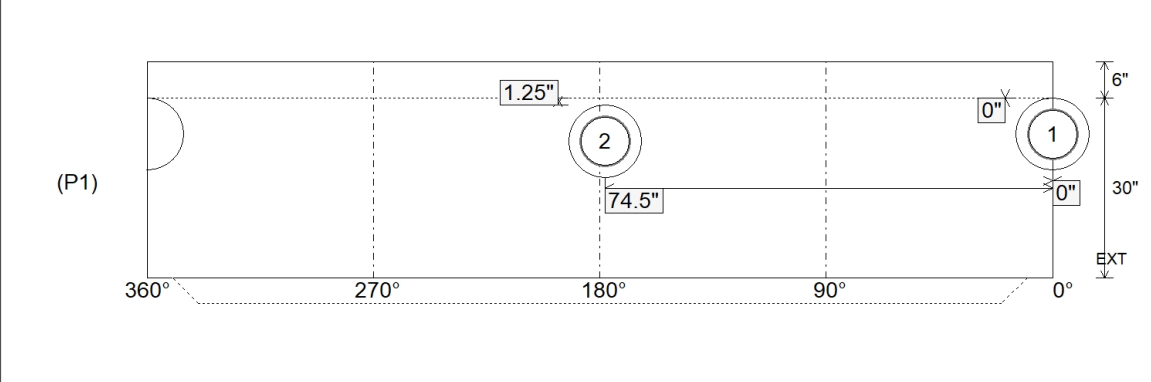

|                                  |                                 |  |  |  |
|----------------------------------|---------------------------------|--|--|--|
| Coating (Int):<br>Coating (Ext): | Seam Up: Tongue<br>Seam Dn: n/a | Wall Thickness: 5"<br>Floor Height: 6" | Height (Int): 30"<br>Height (Ext): 36" | Weight (Net): 3330 lb<br>Volume (Net): 0.85cu.yd |
|----------------------------------|---------------------------------|--|--|--|

Job Name: 25-2310 GOOSE CREEK SUBDIVISION  
 Job Location: Hartsville, TN  
 Contractor: Hayes Pipe Supply

Plant: Beaver Dam

Tech: C.Russ

2/4/2026 12:36:19 PM

PC: A.Chambers



**Structure ID: SSMH 2**

**P1A MH048BA30CDARED**

**MH BASE w/ConBlock-CDA Red T/n**

- P4) 24" - CASTING HEIGHT - 7.50"
- P3) 48" - ECC CONE w/ 24" HOLE, w/ConBlock-CDA Red F/G - 30"
- P2) 48" - MH RISER w/ConBlock-CDA Red T/G - 36"
- P1) 48" - MH BASE w/ConBlock-CDA Red T/n - 30"
- 1) JOINT WRAP - 0.065"x6"x50' CONSEAL CS212
- 1) JOINT WRAP PRIMER - CONSEAL CS-75 (1 gal.)
- 1) ADMIXTURE CONBLOCK CDA RED
- 1) 48" - MH INVERT CHANNEL w/ConBlock-CDA Red - FULL HEIGHT
- 2) 48" - Conseal CS-102 1.00" (Double)
- 2) PSX - 12-08 NYLO
- 8) MH Step ML-10-TDS-NCR - 10"

0 lb  
 1961 lb  
 2515 lb  
 3330 lb  
 0 lb  
 0 lb  
 0 lb  
 1440 lb  
 0 lb  
 16 lb  
 0 lb  
 -----  
 Structure Total: 9263 lb

Structure Notes:

1. PER ASTM C478 SPECIFICATIONS.
2. CONCRETE = 4,000 PSI AT 28 DAYS.
3. ADMIXTURE = CONBLOCK-CDA RED.
4. CASTING BY OTHERS (JBS 1150 F/C).

REINFORCING PER ASTM A615 (GRADE 60).

- CONE (As .12)
- RISER (As .12)
- FLOOR (As .31) #5 BARS AT 12" C.C.E.W.

Rim: 476' Rim to Invert: 8.47' Slack: 0.14" Sump: 2" Step Position: 270°

| Position | Elev    | Angle | Ext. (cw) | Pipe         | Pipe OD | Connector      | Hole | Horz Size | Up ( ) | Offset |
|----------|---------|-------|-----------|--------------|---------|----------------|------|-----------|--------|--------|
| Invert 1 | 467.53' | 0°    | 0"        | 8" PVC SDR26 | 8.5"    | PSX 12-08 NYLO | 12"  | 12.129"   | 0"     | 0"     |
| Invert 2 | 467.63' | 178°  | 90.125"   | 8" PVC SDR26 | 8.5"    | PSX 12-08 NYLO | 12"  | 12.129"   | 1.25"  | 0"     |
| Invert 3 |         |       |           |              |         |                |      |           |        |        |
| Invert 4 |         |       |           |              |         |                |      |           |        |        |
| Invert 5 |         |       |           |              |         |                |      |           |        |        |
| Invert 6 |         |       |           |              |         |                |      |           |        |        |
| Invert 7 |         |       |           |              |         |                |      |           |        |        |
| Invert 8 |         |       |           |              |         |                |      |           |        |        |

RIGHT-SIDE UP VIEW (int. dimensions)

UPSIDE-DOWN VIEW (int. dimensions)

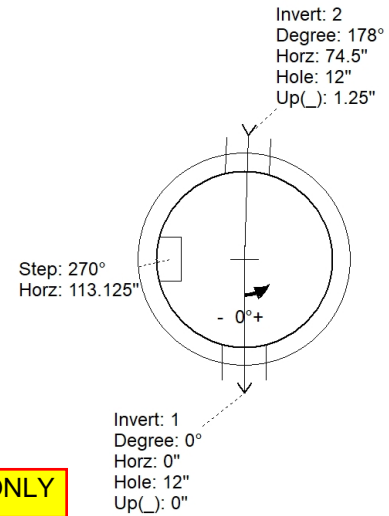
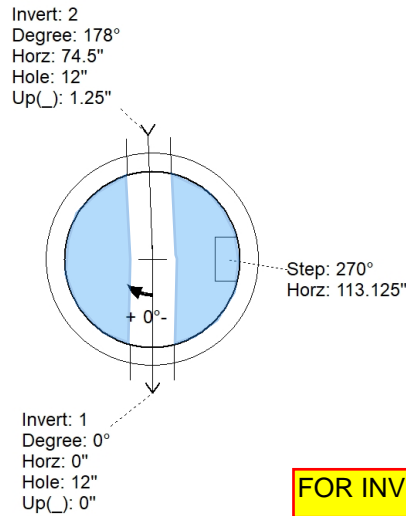

FOR INVERT ONLY

INSIDE WALL DIMENSIONS

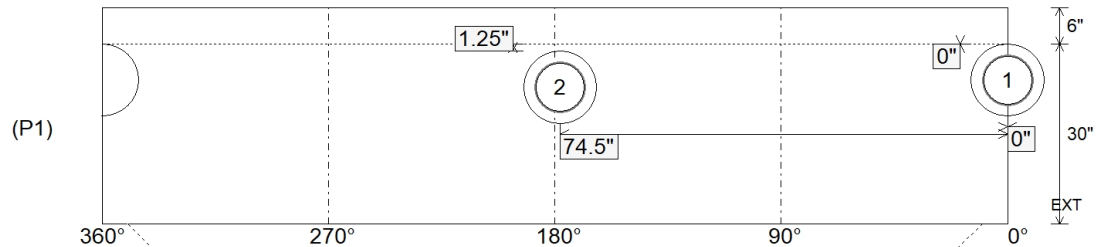

Coating (Int):  
 Coating (Ext):

Seam Up: Tongue  
 Seam Dn: n/a

Wall Thickness: 5"  
 Floor Height: 6"

Height (Int): 30"  
 Height (Ext): 36"

Weight (Net): 3330 lb  
 Volume (Net): 0.85cu.yd