

Job Name: 25-2290 - AutoZone 9385	Plant: 100	Tech: J. Horsley - A	
Job Location: Louisville, KY	2/23/2026 10:31:18 AM	PC: Jay Ross Jarvis	
Contractor: Cornell Harbison Excavating			

**Structure ID: 6-1**

**P1 BX2436-08BVF**

**BOX BASE 8inW, 8inF, Variable Ht T/n**

P3) 24" x 120" - CB INLET KY A 10' TOP LEFT F/G - 10"	3400 lb
P2) 24" x 120" - CB INLET KY A 10' BOTTOM LEFT T/G - 18"	5270 lb
P1) 24" x 36" - BOX BASE 8inW, 8inF, Variable Ht T/n - 28"	4042 lb
1) CASTING - HOE KY-206 F/C (KY TY1)	206 lb
1) This Structure Includes a Cast-in Item - HOE KY-206 Frame Flange Side Up	0 lb
1) 24" x 36" - Conseal CS-102 1.00"	0 lb
1) Hole - 20	0 lb
<b>Structure Total:</b>	<b>12918 lb</b>

**Structure Notes:**

- PER KYTC CBI TY A / ASTM C-913 SPECIFICATIONS
- CONCRETE: 4,000 PSI AT 28 DAYS
- REINFORCEMENT: #5 BAR @ 12" C.C. E.W. (GRADE 60) - 2" MIN. REBAR CLEARANCE (TYP)
- NO STORM INVERT
- NO STEPS
- HOE KY-206 FRAME & COVER "STORM" SUPPLIED BY ICAST - FRAME TO BE CAST INTO TOP PHASE TOP FLANGE SIDE UP

Rim: 453.26' Rim to Invert: 4.71' Slack: 0.52" Sump: 0" Step Position:

Position	Elev	Angle	Ext. (cw)	Pipe	Pipe OD	Connector	Hole	Horz Size	Up ( )	Offset
Invert 1	448.55'	180°	20"	12" RCP B WALL	16"	Hole 20	20"	20"	-4"	0"
Invert 2										
Invert 3										
Invert 4										
Invert 5										
Invert 6										
Invert 7										
Invert 8										

RIGHT-SIDE UP VIEW (int. dimensions)

UPSIDE-DOWN VIEW (int. dimensions)

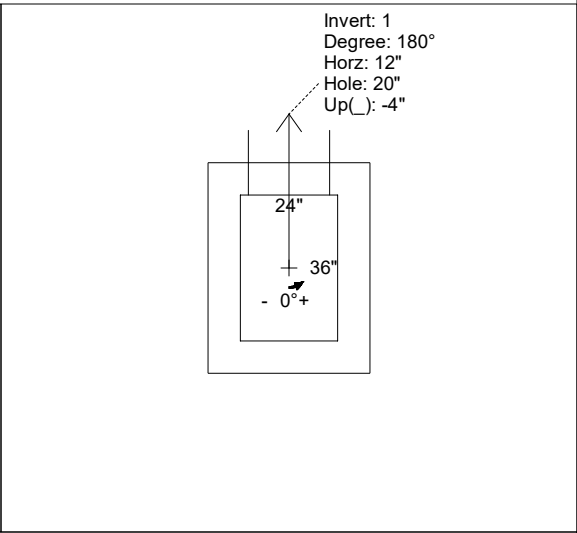
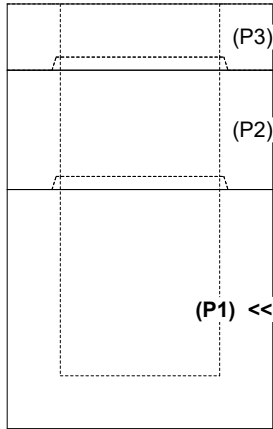

INSIDE WALL DIMENSIONS

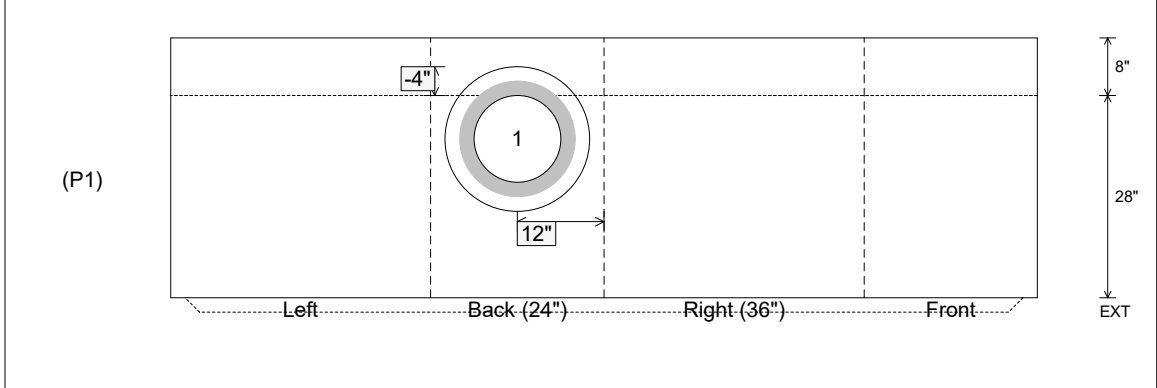

Coating (Int): Coating (Ext):	Seam Up: Tongue Seam Dn: n/a	Wall Thickness: 8" Floor Height: 8"	Height (Int): 28" Height (Ext): 36"	Weight (Net): 4042 lb Volume (Net): 1.03cu.yd
----------------------------------	---------------------------------	--	--	--