

Job Name: 25-2059 New Vista Expansion
 Job Location: Danville, KY
 Contractor: Louisville Paving and Construction

Plant: Beaver Dam

10/15/2025 12:08:21 PM

Tech: J. Coppage

PC: J. Jarvis



Structure ID: OCS

P1 BX2424-08BAVF

BOX BASE 8inW, 8inF, Variable Ht

- P2) 24" x 24" - CASTING HEIGHT - 0"
- P1) 24" x 24" - BOX BASE 8inW, 8inF, Variable Ht - 44"
- 1) CASTING - TRASHRACKS LFS-2424-P SQ. Flush Mount Grate
- 1) 24" x 24" - SGL 1"x14.5' Butyl
- 1) Hole - 22
- 1) Hole - 8
- 1) Weir - 11"x14.4"

- Structure Notes:**
1. TRASHRACK LFS-2424 PROVIDED BY ICAST.
 2. PER ASTM C913 SPECIFICATIONS.
 3. CONCRETE = 4,000 PSI AT 28 DAYS.
 4. REINFORCING PER ASTM A615 (GRADE 60).
 - TOP SLAB (As .62) #5 BARS AT 6" C.C.E.W.
 - WALLS (As .12) #5 BARS AT 12" C.C.E.W.
 - FLOOR (As .12) #5 BARS AT 12" C.C.E.W.

Structure Total: 4522 lb

Rim: 967.7' Rim to Invert: 3.7' Slack: 0.4" Sump: 0" Step Position:

Position	Elev	Angle	Ext. (cw)	Pipe	Pipe OD	Connector	Hole	Horz Size	Up ()	Offset
Invert 1	964'	0°	20"	15" RCP B WALL	19.5"	Hole 22	22"	22"	-2.25"	0"
Invert 2	964'	180°	20"	6" PVC SCH40	6.625"	Hole 8	8"	8"	-0.297"	0"
Invert 3	966.5'	180°	20"	11" x 14.4" Weir	11" x 14.4"	Weir 11"x14.4"	11" x 14.4"	11"	30"	0"
Invert 4										
Invert 5										
Invert 6										
Invert 7										
Invert 8										

RIGHT-SIDE UP VIEW (int. dimensions)

UPSIDE-DOWN VIEW (int. dimensions)

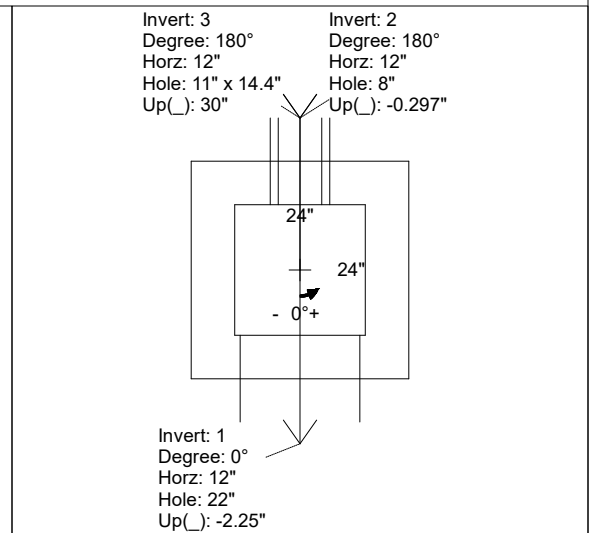
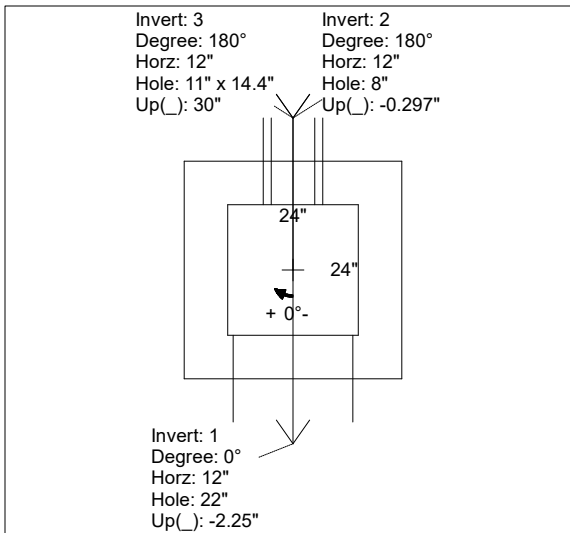
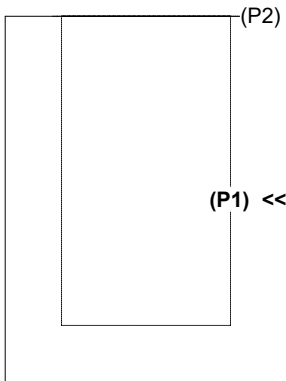

INSIDE WALL DIMENSIONS

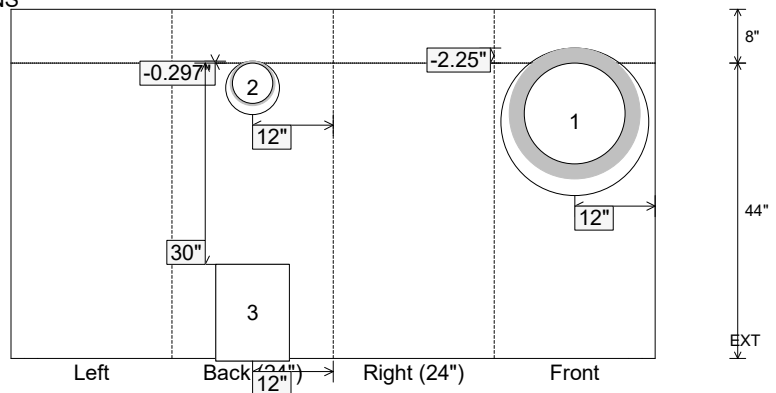

Coating (Int): Coating (Ext):	Seam Up: Flat Seam Dn: n/a	Wall Thickness: 8" Floor Height: 8"	Height (Int): 44" Height (Ext): 52"	Weight (Net): 4463 lb Volume (Net): 1.14cu.yd
----------------------------------	-------------------------------	--	--	--