

Job Name: 25-2054 - South US 27 Ph 2 Sewer Extension
 Job Location: Somerset, KY 42501
 Contractor: Weddle Enterprises, Inc

Plant: Beaver Dam, KY
 10/23/2025 2:01:38 PM

Tech: K. Cardwell
 PC: C. Goff



Structure ID: MH A-7

P3 MH048CN30CDARED

ECC CONE w/ 24" HOLE, w/ConBlock-CDA Red F/G

P5) 24" - CASTING HEIGHT - 7"	0 lb
P4) 24" - GRADE RING w/ConBlock-CDA Red F/F - 4"	270 lb
P3) 48" - ECC CONE w/ 24" HOLE, w/ConBlock-CDA Red F/G - 30"	1961 lb
P2) 48" - MH RISER w/ConBlock-CDA Red T/G - 36"	2515 lb
P1) 48" - MH BASE w/ConBlock-CDA Red T/n - 24"	2890 lb
1) JOINT WRAP PRIMER - CONSEAL CS-75 (1 gal.)	0 lb
1) JOINT WRAP - 0.065"x6"x50" CONSEAL CS212	0 lb
1) ADMIXTURE CONBLOCK CDA RED	0 lb
1) 48" - MH INVERT CHANNEL w/ConBlock-CDA Red - FULL HEIGHT	1440 lb
2) 48" - Conseal CS-102 1.00" (Double)	0 lb
2) PSX - 12-08 NYLO	16 lb
1) PSX - 8QRS-S NYLO	6 lb
8) MH Step ML-10-TDS-NCR - 10"	0 lb
Structure Total:	9099 lb

Structure Notes:
 STATION: 14+58 LINE "A"
 1. PER ASTM C-478 SPECS
 2. CONCRETE: 5,000 PSI AT 28 DAYS
 3. REINFORCEMENT: PER ASTM A615
 4. INVERT CHANNEL REQUIRED
 5. CONBLOCK CDA RED ADMIXTURE REQUIRED
 6. 7" CASTING SUPPLIED BY OTHERS
 7. STEPS AT 0 DEGREES

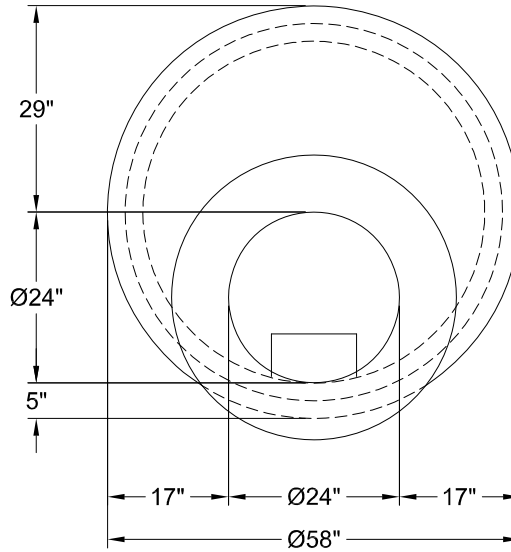

48" - ECC CONE w/ 24" HOLE, w/ConBlock-CDA Red F/G - 30" - (P3)



Coating (Int):
 Coating (Ext):

Seam Up: Flat
 Seam Dn: Groove

Wall Thickness: 5"

Height (Ext): 30"

Weight (Net): 1961 lb
 Volume (Net): 0.5cu.yd