

Job Name: 25-2054 - South US 27 Ph 2 Sewer Extension
Job Location: Somerset, KY 42501
Contractor: Weddle Enterprises, Inc

PC: C. Goff
 TECH: K. Cardwell
 Plant: Beaver Dam, KY



Structure ID: **MH A-5**

Spec: Sanitary
 Type: SAN.MH w/ConBlock-CDA Red
 Size: 48"

Rim: 889.29'
 Invert: 881.42'
 Rim to Invert: 7.87'

Sump: 2"
 Floor (Top): 881.253'
 Floor Height: 6"

Floor (Bot): 880.753'
 Overall Height: 8.417'
 Slack: 1.44"

Structure Notes:

- STATION: 9+38 LINE "A"
 1. PER ASTM C-478 SPECS
 2. CONCRETE: 5,000 PSI AT 28 DAYS
 3. REINFORCEMENT: PER ASTM A615
 4. INVERT CHANNEL REQUIRED
 5. CONBLOCK CDA RED ADMIXTURE REQUIRED
 6. 7" CASTING SUPPLIED BY OTHERS
 7. STEPS AT 0 DEGREES

STRUCTURE SUMMARY:

- P5) 24" - CASTING HEIGHT - 7" 0 lb
 - P4) 24" - GRADE RING w/ConBlock-CDA Red F/F - 4" 270 lb
 - P3) 48" - ECC CONE w/ 24" HOLE, w/ConBlock-CDA Red F/G - 36" 2251 lb
 - P2) 48" - MH RISER w/ConBlock-CDA Red T/G - 24" 1677 lb
 - P1) 48" - MH BASE w/ConBlock-CDA Red T/n - 24" 2911 lb
 - 1) JOINT WRAP PRIMER - CONSEAL CS-75 (1 gal.) 0 lb
 - 1) JOINT WRAP - 0.065"x6"x50' CONSEAL CS212 0 lb
 - 1) ADMIXTURE CONBLOCK CDA RED 0 lb
 - 1) 48" - MH INVERT CHANNEL w/ConBlock-CDA Red - FULL HEIGHT 1440 lb
 - 2) 48" - Conseal CS-102 1.00" (Double) 0 lb
 - 2) PSX - 12-08 NYLO 16 lb
 - 7) MH Step ML-10-TDS-NCR - 10" 0 lb
- Structure Total: 8565 lb**

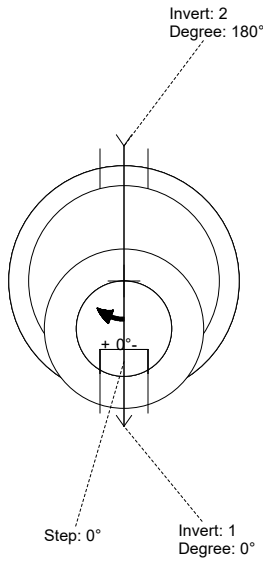

Position	Elev	Angle	Pipe	Pipe OD	Hole	Connector	Up (L)	Ref
Rim	889.29'							
Reducer								
Invert 1	881.42'	0°	8" PVC SDR35	8.5"	12"	PSX 12-08 NYLO	0"	P1
Invert 2	881.52'	180°	8" PVC SDR35	8.5"	12"	PSX 12-08 NYLO	1.2"	P1
Invert 3								
Invert 4								
Invert 5								
Invert 6								
Invert 7								
Invert 8								

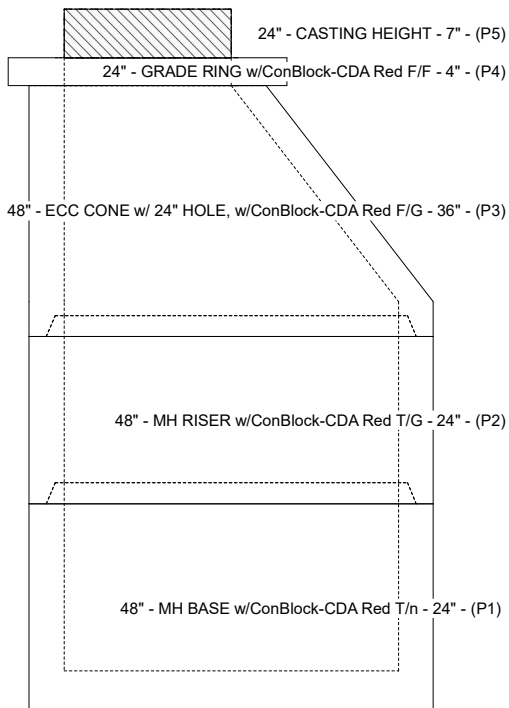

Cast (Int. Dim.) - Interior Dimensions

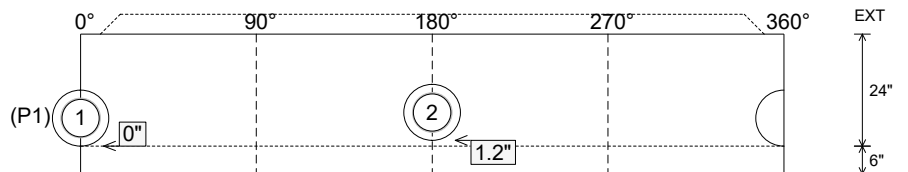

Submittal Drawing
 10/23/2025 1:12:08 PM

SUBMITTAL
 APPROVED BY: