

Job Name: 25-2054 - South US 27 Ph 2 Sewer Extension
 Job Location: Somerset, KY 42501
 Contractor: Weddle Enterprises, Inc

Plant: Beaver Dam, KY
 10/23/2025 2:00:52 PM

Tech: K. Cardwell
 PC: C. Goff



Structure ID: MH A-5

P1 MH048BA24CDARED

MH BASE w/ConBlock-CDA Red T/n

- P5) 24" - CASTING HEIGHT - 7" 0 lb
 - P4) 24" - GRADE RING w/ConBlock-CDA Red F/F - 4" 270 lb
 - P3) 48" - ECC CONE w/ 24" HOLE, w/ConBlock-CDA Red F/G - 36" 2251 lb
 - P2) 48" - MH RISER w/ConBlock-CDA Red T/G - 24" 1677 lb
 - P1) 48" - MH BASE w/ConBlock-CDA Red T/n - 24" 2911 lb
 - 1) JOINT WRAP PRIMER - CONSEAL CS-75 (1 gal.) 0 lb
 - 1) JOINT WRAP - 0.065"x6"x50" CONSEAL CS212 0 lb
 - 1) ADMIXTURE CONBLOCK CDA RED 0 lb
 - 1) 48" - MH INVERT CHANNEL w/ConBlock-CDA Red - FULL HEIGHT 1440 lb
 - 2) 48" - Conseal CS-102 1.00" (Double) 0 lb
 - 2) PSX - 12-08 NYLO 16 lb
 - 7) MH Step ML-10-TDS-NCR - 10" 0 lb
- Structure Total: 8565 lb

Structure Notes:
 STATION: 9+38 LINE "A"
 1. PER ASTM C-478 SPECS
 2. CONCRETE: 5,000 PSI AT 28 DAYS
 3. REINFORCEMENT: PER ASTM A615
 4. INVERT CHANNEL REQUIRED
 5. CONBLOCK CDA RED ADMIXTURE REQUIRED
 6. 7" CASTING SUPPLIED BY OTHERS
 7. STEPS AT 0 DEGREES

Rim: 889.29' Rim to Invert: 7.87' Slack: 1.44" Sump: 2" Step Position: 0°

Position	Elev	Angle	Ext. (cw)	Pipe	Pipe OD	Connector	Hole	Horz Size	Up ()	Offset
Invert 1	881.42'	0°	0"	8" PVC SDR35	8.5"	PSX 12-08 NYLO	12"	12.129"	0"	0"
Invert 2	881.52'	180°	91.106"	8" PVC SDR35	8.5"	PSX 12-08 NYLO	12"	12.129"	1.2"	0"
Invert 3										
Invert 4										
Invert 5										
Invert 6										
Invert 7										
Invert 8										

RIGHT-SIDE UP VIEW (int. dimensions)

UPSIDE-DOWN VIEW (int. dimensions)

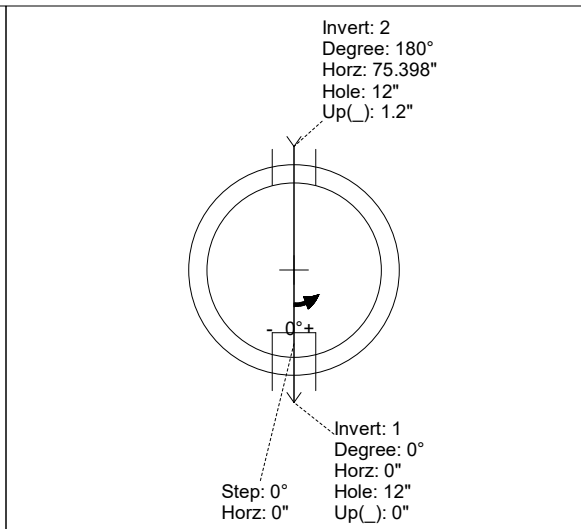
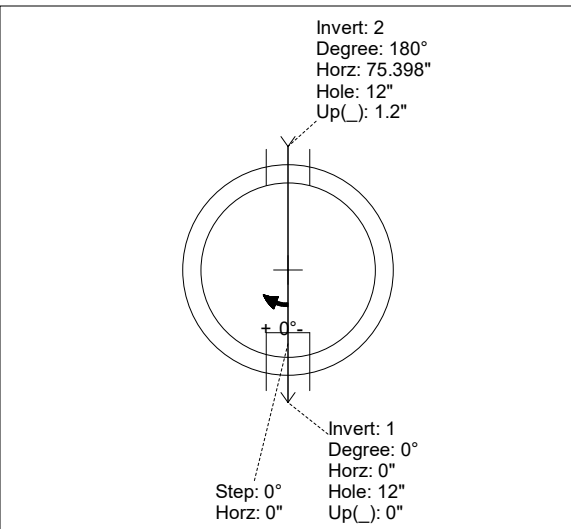
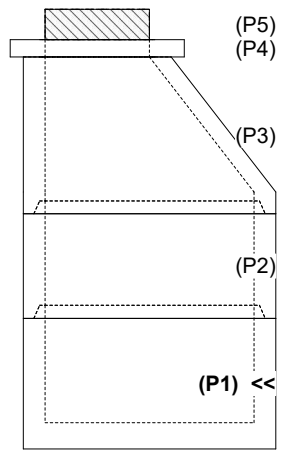

INSIDE WALL DIMENSIONS

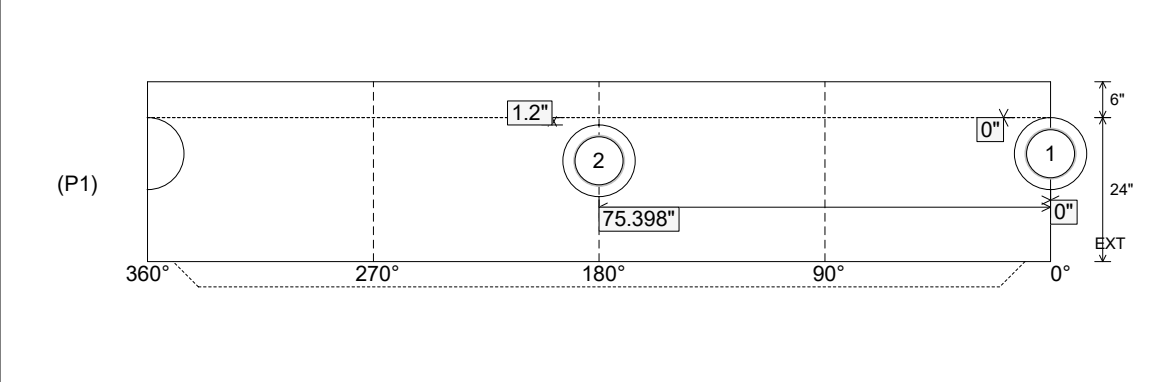

Coating (Int): Coating (Ext):	Seam Up: Tongue Seam Dn: n/a	Wall Thickness: 5" Floor Height: 6"	Height (Int): 24" Height (Ext): 30"	Weight (Net): 2911 lb Volume (Net): 0.74cu.yd
----------------------------------	---------------------------------	--	--	--

Job Name: 25-2054 - South US 27 Ph 2 Sewer Extension
 Job Location: Somerset, KY 42501
 Contractor: Weddle Enterprises, Inc

Plant: Beaver Dam, KY
 10/23/2025 2:00:52 PM

Tech: K. Cardwell
 PC: C. Goff



Structure ID: MH A-5

P1 MH048BA24CDARED

MH BASE w/ConBlock-CDA Red T/n

- P5) 24" - CASTING HEIGHT - 7" 0 lb
 - P4) 24" - GRADE RING w/ConBlock-CDA Red F/F - 4" 270 lb
 - P3) 48" - ECC CONE w/ 24" HOLE, w/ConBlock-CDA Red F/G - 36" 2251 lb
 - P2) 48" - MH RISER w/ConBlock-CDA Red T/G - 24" 1677 lb
 - P1) 48" - MH BASE w/ConBlock-CDA Red T/n - 24" 2911 lb
 - 1) JOINT WRAP PRIMER - CONSEAL CS-75 (1 gal.) 0 lb
 - 1) JOINT WRAP - 0.065"x6"x50" CONSEAL CS212 0 lb
 - 1) ADMIXTURE CONBLOCK CDA RED 0 lb
 - 1) 48" - MH INVERT CHANNEL w/ConBlock-CDA Red - FULL HEIGHT 1440 lb
 - 2) 48" - Conseal CS-102 1.00" (Double) 0 lb
 - 2) PSX - 12-08 NYLO 16 lb
 - 7) MH Step ML-10-TDS-NCR - 10" 0 lb
- Structure Total: 8565 lb

Structure Notes:
 STATION: 9+38 LINE "A"
 1. PER ASTM C-478 SPECS
 2. CONCRETE: 5,000 PSI AT 28 DAYS
 3. REINFORCEMENT: PER ASTM A615
 4. INVERT CHANNEL REQUIRED
 5. CONBLOCK CDA RED ADMIXTURE REQUIRED
 6. 7" CASTING SUPPLIED BY OTHERS
 7. STEPS AT 0 DEGREES

Rim: 889.29' Rim to Invert: 7.87' Slack: 1.44" Sump: 2" Step Position: 0°

Position	Elev	Angle	Ext. (cw)	Pipe	Pipe OD	Connector	Hole	Horz Size	Up ()	Offset
Invert 1	881.42'	0°	0"	8" PVC SDR35	8.5"	PSX 12-08 NYLO	12"	12.129"	0"	0"
Invert 2	881.52'	180°	91.106"	8" PVC SDR35	8.5"	PSX 12-08 NYLO	12"	12.129"	1.2"	0"
Invert 3										
Invert 4										
Invert 5										
Invert 6										
Invert 7										
Invert 8										

RIGHT-SIDE UP VIEW (int. dimensions)

UPSIDE-DOWN VIEW (int. dimensions)

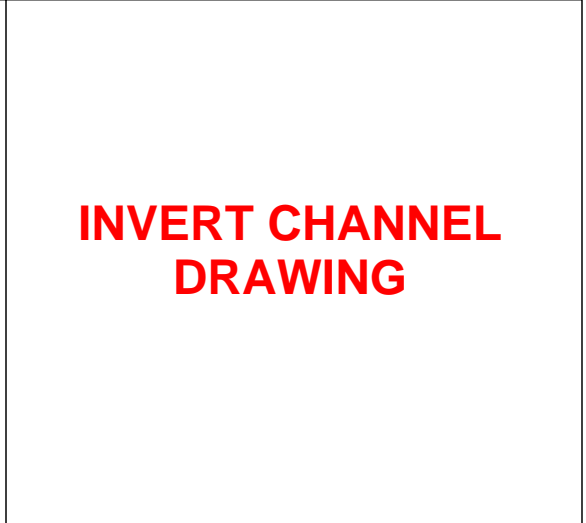
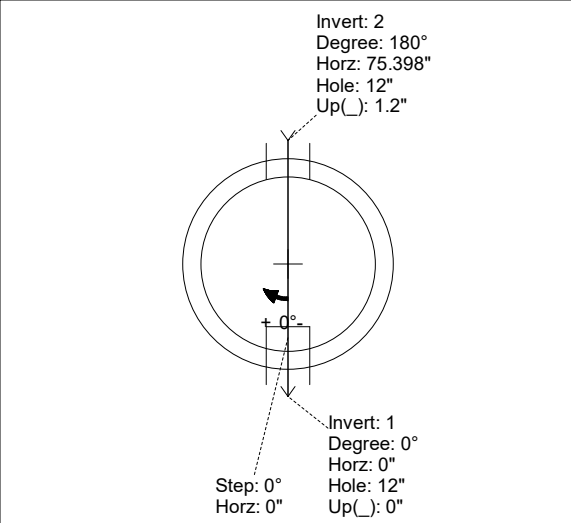
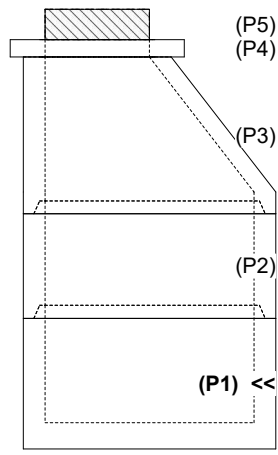

INSIDE WALL DIMENSIONS

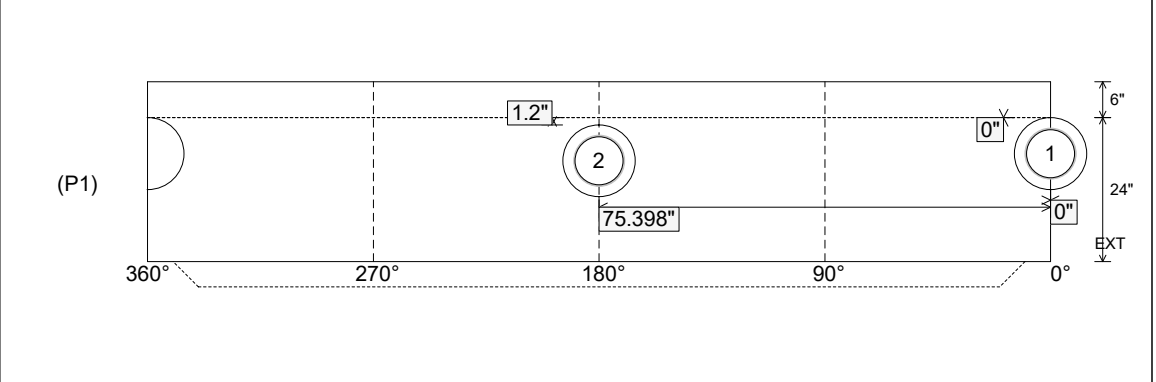

Coating (Int): Coating (Ext):	Seam Up: Tongue Seam Dn: n/a	Wall Thickness: 5" Floor Height: 6"	Height (Int): 24" Height (Ext): 30"	Weight (Net): 2911 lb Volume (Net): 0.74cu.yd
----------------------------------	---------------------------------	--	--	--