

Job Name: 25-2054 - South US 27 Ph 2 Sewer Extension  
 Job Location: Somerset, KY 42501  
 Contractor: Weddle Enterprises, Inc

Plant: Beaver Dam, KY  
 10/23/2025 2:01:35 PM

Tech: K. Cardwell  
 PC: C. Goff



**Structure ID: MH A-2**

**P2 MH048CN24CDARED**

**ECC CONE w/ 24" HOLE, w/ConBlock-CDA Red F/G**

- P3) 24" - CASTING HEIGHT - 7"
- P2) 48" - ECC CONE w/ 24" HOLE, w/ConBlock-CDA Red F/G - 24"
- P1) 48" - MH BASE w/ConBlock-CDA Red T/n - 24"
- 1) JOINT WRAP PRIMER - CONSEAL CS-75 (1 gal.)
- 1) JOINT WRAP - 0.065"x6"x50' CONSEAL CS212
- 1) ADMIXTURE CONBLOCK CDA RED
- 1) 48" - MH INVERT CHANNEL w/ConBlock-CDA Red - FULL HEIGHT
- 1) 48" - Conseal CS-102 1.00" (Double)
- 2) PSX - 12-08 NYLO
- 4) MH Step ML-10-TDS-NCR - 10"

0 lb  
 1738 lb  
 2911 lb  
 0 lb  
 0 lb  
 0 lb  
 1440 lb  
 0 lb  
 16 lb  
 0 lb  
 -----  
 Structure Total: 6105 lb

- Structure Notes:  
 STATION: 2+00 LINE "A"
1. PER ASTM C-478 SPECS
  2. CONCRETE: 5,000 PSI AT 28 DAYS
  3. REINFORCEMENT: PER ASTM A615
  4. INVERT CHANNEL REQUIRED
  5. CONBLOCK CDA RED ADMIXTURE REQUIRED
  6. 7" CASTING SUPPLIED BY OTHERS
  7. STEPS AT 0 DEGREES

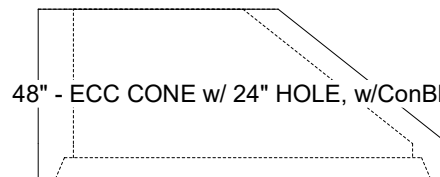
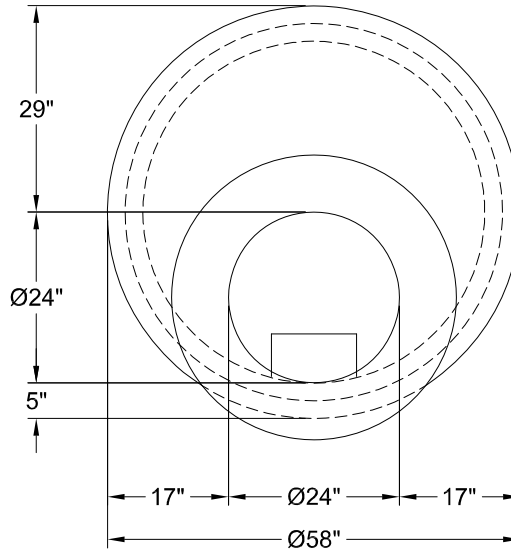

48" - ECC CONE w/ 24" HOLE, w/ConBlock-CDA Red F/G - 24" - (P2)

Coating (Int):  
 Coating (Ext):

Seam Up: Flat  
 Seam Dn: Groove

Wall Thickness: 5"

Height (Ext): 24"

Weight (Net): 1738 lb  
 Volume (Net): 0.44cu.yd