

Job Name: 25-2054 - South US 27 Ph 2 Sewer Extension
 Job Location: Somerset, KY 42501
 Contractor: Weddle Enterprises, Inc

Plant: Beaver Dam, KY

Tech: K. Cardwell

10/23/2025 3:41:24 PM

PC: C. Goff

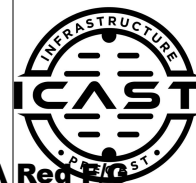

Structure ID: ARV 6+50

P2 MH048LD12CDARED

MH FLAT TOP w/24" Hole ECC w/ConBlock-CDA Red F/G

- P3) 24" - CASTING HEIGHT - 7"
- P2) 48" - MH FLAT TOP w/24" Hole ECC w/ConBlock-CDA Red F/G - 12"
- P1) 48" - MH DH RISER Custom Ht, w/ConBlock-CDA Red T/F - 35"
- 1) JOINT WRAP PRIMER - CONSEAL CS-75 (1 gal.)
- 1) JOINT WRAP - 0.065"x6"x50' CONSEAL CS212
- 1) ADMIXTURE CONBLOCK CDA RED
- 1) 48" - Conseal CS-102 1.00" (Double)
- 1) No Openings
- 3) MH Step ML-10-TDS-NCR - 10"

0 lb
 1580 lb
 2445 lb
 0 lb
 0 lb
 0 lb
 0 lb
 0 lb
 0 lb
 0 lb

 Structure Total: 4025 lb

- Structure Notes:
 STATION: 6+50
1. PER ASMT C-478 SPECS
 2. CONCRETE: 5,000 PSI AT 28 DAYS
 3. REINFORCEMENT: PER ASTM A615
 4. CONBLOCK CDA RED ADMIXTURE REQUIRED
 5. 7" CASTING SUPPLIED BY OTHERS
 6. STEPS AT 0 DEGREES
 7. LIFTERS: 3 EA. WRA016 CONAC WIRE ROPE ANCHORS FOR PLANT & FIELD HANDLING

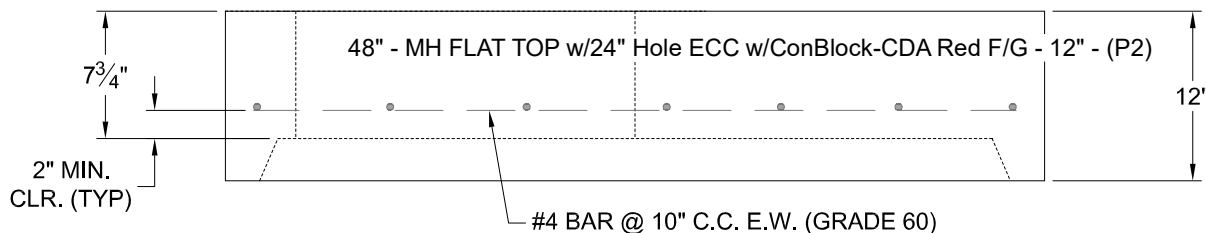
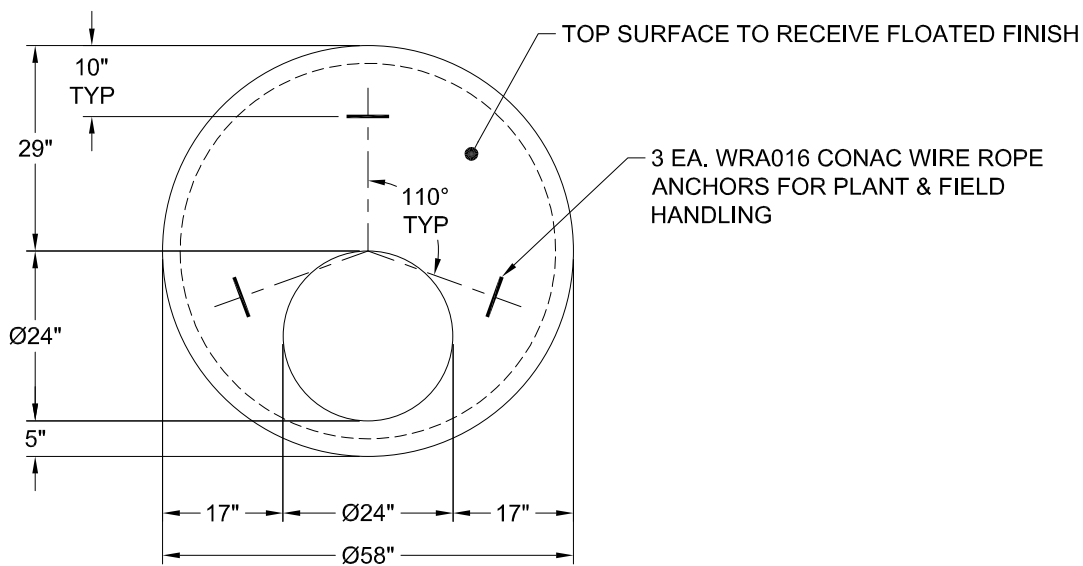

Coating (Int):
 Coating (Ext):

Seam Up: Flat
 Seam Dn: Groove

Wall Thickness: 5"

Height (Ext): 12"

Weight (Net): 1580 lb
 Volume (Net): 0.39cu.yd