

**Job Name: 25-1965 ACEE'S MARKET & DELI**  
**Job Location: Fulton, KY**  
**Contractor: Rinker Underground**

PC: J.Jarvis  
 TECH: J. Coppage  
 Plant: Beaver Dam



Structure ID: **ST 9**  
 Spec: KYTC  
 Type: CBI TYPE A (5') MOD.  
 Size: 24" x 60"

Rim: 415.58'  
 Invert: 411.08'  
 Rim to Invert: 4.5'

Sump: 0"  
 Floor (Top): 411.08'  
 Floor Height: 8"

Floor (Bot): 410.413'  
 Overall Height: 5.167'  
 Slack: 0"

**Structure Notes:**

1. PER KYTC CBI TYPE A 5' (MOD) / ASTM C913 SPEC'S
2. CONCRETE = 4,000 PI AT 28 DAYS
3. REINFORCING PER ASTM A615 (GRADE 60)
  - TOP PHASE (As .62) #5 BARS AT 6" C.C.E.W.
  - WALLS (As .31) #5 BARS AT 12" C.C.E.W.
  - FLOOR (As .31) #5 BARS AT 12" C.C.E.W.
4. HOE KY-206 PROVIDED BY ICAST
5. #5 BAR @ 12" C.C. TO BE STUBBED OUT OF 8" DEEP THROAT (INVERT 3) FOR GUTTER POUR TIE-IN

**STRUCTURE SUMMARY:**

P2) 24" x 60" - CB INLET KY A 5' TOP LEFT - 10"	1895 lb
P1) 24" x 60" - BOX BASE 8inW, 8inF, Variable Ht - 44"	7292 lb
1) CASTING - HOE KY-206 F/C (KY TY1)	206 lb
1) 24" x 60" - Conseal CS-102 1.00"	0 lb
1) SQ. Hole - 20"x20"	0 lb
1) SQ. Hole - 12"x12"	0 lb
1) Horiz Slot - 60"x8"	0 lb
<b>Structure Total:</b>	<b>9393 lb</b>

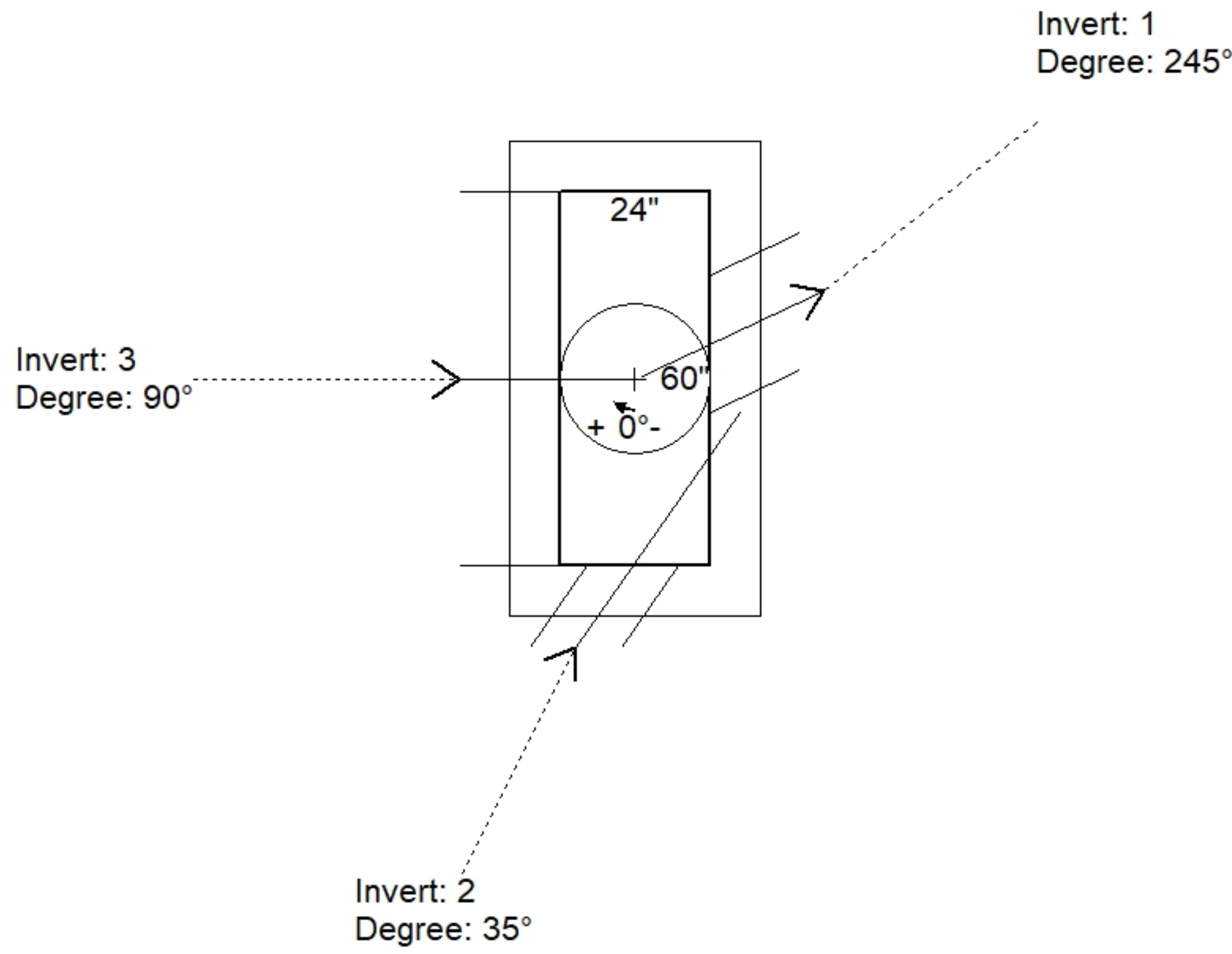

Position	Elev	Angle	Pipe	Pipe OD	Hole	Connector	Up (")	Ref
Rim	415.58'							
Reducer								
Invert 1	411.08'	245°	12" RCP B WALL	16"	20" x 20"	SQ. Hole 20"x20"	-4"	P1
Invert 2	411.08'	35°	8" PVC SDR26	8.5"	12" x 12"	SQ. Hole 12"x12"	-2"	P1
Invert 3	414.08'	90°	60" x 8" Horiz Slot	60" x 8"	60" x 8"	Horiz Slot 60"x8"	36"	P1
Invert 4								
Invert 5								
Invert 6								
Invert 7								
Invert 8								

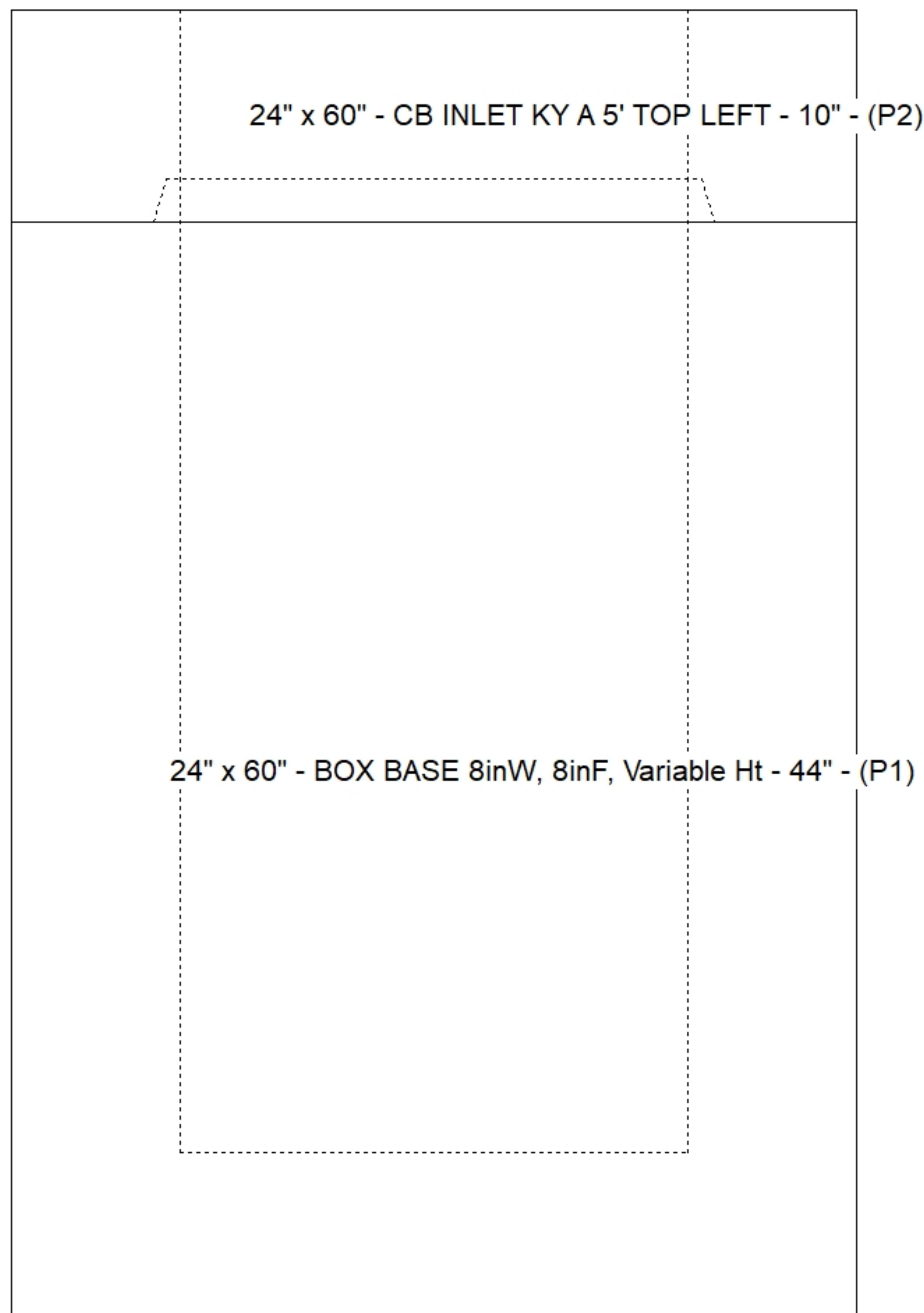

**Default - Interior Dimensions**

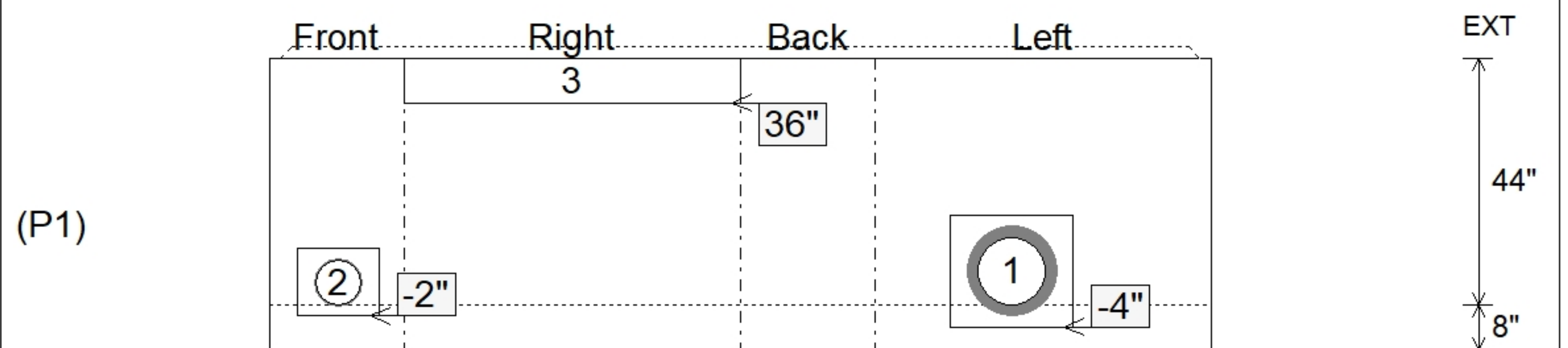

Submittal Drawing  
 12/2/2025 10:10:46 AM

SUBMITTAL  
 APPROVED BY: