

Job Name: 25-1951 - Speedway Site Design  
 Job Location: Horse Cave, KY  
 Contractor: Scotty's Contracting & Stone, LLC

Plant: 100

Tech: J. Horsley - F

12/3/2025 8:14:13 AM

PC: C. Goff



**Structure ID: 6**

**P1 BX2424-08BA36**

**BOX BASE 8inW, 8inF F/n**

- P2) 24" x 24" - CASTING HEIGHT - 4"
- P1) 24" x 24" - BOX BASE 8inW, 8inF F/n - 36"
- 1) CASTING - HOE 280T F/G
- 1) 24" x 24" - Conseal CS-102 1.00"
- 2) Hole - 22
- 1) Hole - 6

0 lb  
 3638 lb  
 182 lb  
 0 lb  
 0 lb  
 0 lb  
 -----  
 0 lb  
 Structure Total: 3820 lb

- Structure Notes:**
1. PER ASTM C-913 SPECIFICATIONS
  2. CONCRETE: 4,000 PSI AT 28 DAYS
  3. REINFORCEMENT: #5 BAR @ 12" C.C. E.W. (GRADE 60) - 2" MIN. REBAR CLEARANCE (TYP)
  4. NO STEPS AND NO INVERT CHANNEL
  5. CASTING BY I-CAST (HOE 280T FRAME & GRATE)

Rim: 580.33' Rim to Invert: 2.33' Slack: -0.04" Sump: 12" Step Position:

| Position | Elev    | Angle | Ext. (cw) | Pipe                | Pipe OD | Connector | Hole | Horz Size | Up (↓) | Offset |
|----------|---------|-------|-----------|---------------------|---------|-----------|------|-----------|--------|--------|
| Invert 1 | 578'    | 0°    | 20"       | 15" RCP B WALL      | 19.5"   | Hole 22   | 22"  | 22"       | 9.75"  | 0"     |
| Invert 2 | 578'    | 180°  | 20"       | 15" RCP B WALL      | 19.5"   | Hole 22   | 22"  | 22"       | 9.75"  | 0"     |
| Invert 3 | 578.83' | 270°  | 20"       | 4" HDPE (perf pipe) | 4.8"    | Hole 6    | 6"   | 6"        | 21.56" | 0"     |
| Invert 4 |         |       |           |                     |         |           |      |           |        |        |
| Invert 5 |         |       |           |                     |         |           |      |           |        |        |
| Invert 6 |         |       |           |                     |         |           |      |           |        |        |
| Invert 7 |         |       |           |                     |         |           |      |           |        |        |
| Invert 8 |         |       |           |                     |         |           |      |           |        |        |

RIGHT-SIDE UP VIEW (int. dimensions)

UPSIDE-DOWN VIEW (int. dimensions)

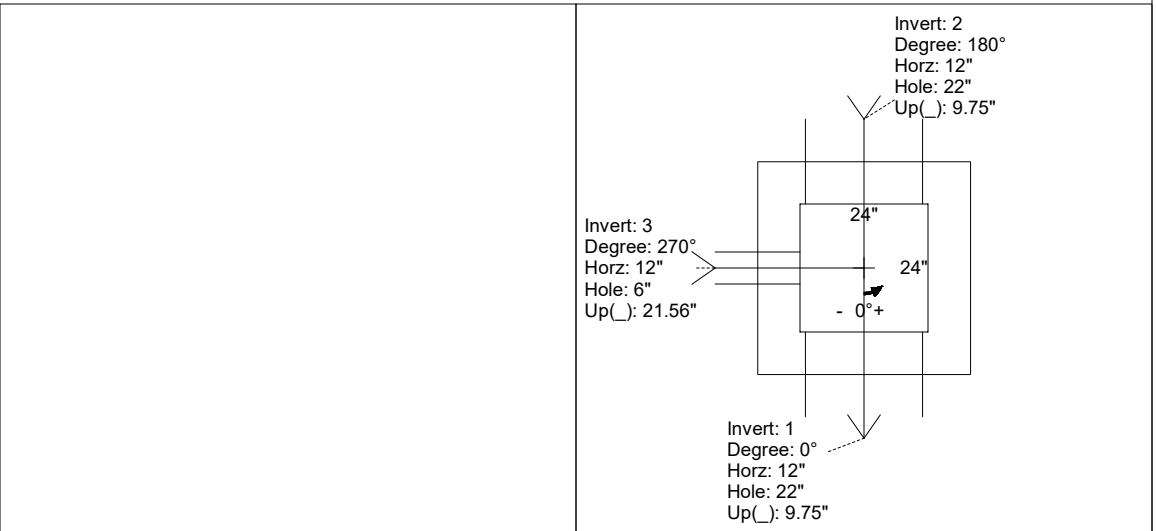
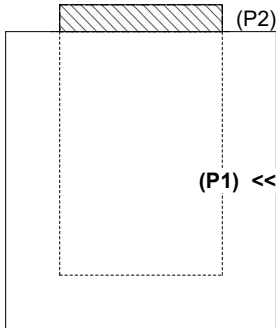

INSIDE WALL DIMENSIONS

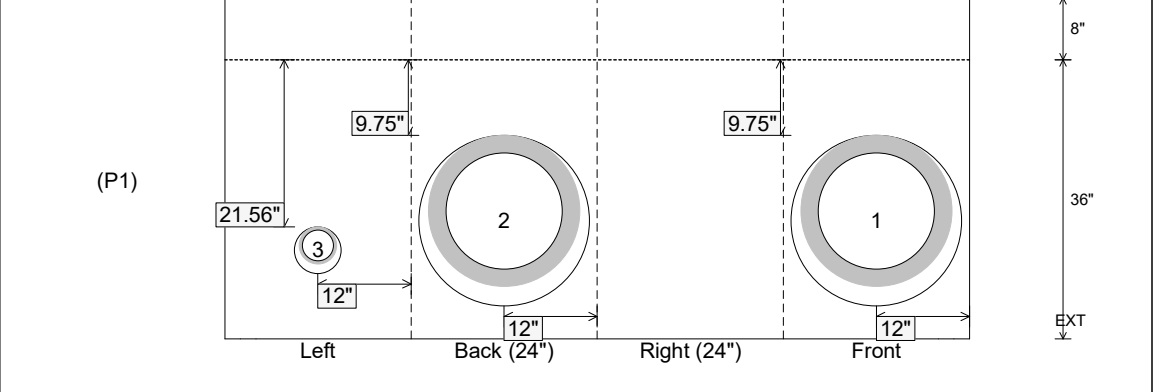

|                                  |                               |  |  |  |
|----------------------------------|-------------------------------|--|--|--|
| Coating (Int):<br>Coating (Ext): | Seam Up: Flat<br>Seam Dn: n/a | Wall Thickness: 8"<br>Floor Height: 8" | Height (Int): 36"<br>Height (Ext): 44" | Weight (Net): 3638 lb<br>Volume (Net): 0.93cu.yd |
|----------------------------------|-------------------------------|--|--|--|