

Job Name: 25-1951 - Speedway Site Design
 Job Location: Horse Cave, KY
 Contractor: Scotty's Contracting & Stone, LLC

Plant: 100
 12/3/2025 8:14:23 AM

Tech: J. Horsley - F
 PC: C. Goff



Structure ID: 102

P1 MH048BAVF

MH BASE Custom Ht F/n

- P3) 36" - CASTING HEIGHT - 6"
- P2) 48" - MH FLAT TOP SPEC. HT. (6") w/36" Hole CC F/F - 6"
- P1) 48" - MH BASE Custom Ht F/n - 33"
- 1) CASTING - HOE MCB-747B Fr./Bar Grate
- 1) 48" - Conseal CS-102 1.00"
- 1) 36" - Conseal CS-102 1.00"
- 1) DOGHOUSE INVRTD - 34"x33"
- 1) Hole - 22
- 3) MH Step ML-10-TDS-NCR - 10"

0 lb
 818 lb
 3013 lb
 675 lb
 0 lb
 0 lb
 0 lb
 0 lb
 0 lb
 0 lb

 Structure Total: 4506 lb

- Structure Notes:**
1. PER ASTM C-478 SPECIFICATIONS
 2. CONCRETE: 4,000 PSI AT 28 DAYS
 3. REINFORCEMENT: PER ASTM A615
 4. NO STEPS AND NO INVERT CHANNEL
 5. CASTING BY I-CAST (HOE MCB-747B FRAME & BAR GRATE)

Rim: 578.85' Rim to Invert: 3.5' Slack: 0" Sump: 3" Step Position: 0°

Position	Elev	Angle	Ext. (cw)	Pipe	Pipe OD	Connector	Hole	Horz Size	Up ()	Offset
Invert 1	575.35'	0°	0"	24" RCP B WALL	30"	DOGHOUSE INVRTD 34"x33"	34" x 33"	37.782"	0"	0"
Invert 2	576'	123°	62.256"	15" RCP B WALL	19.5"	Hole 22	22"	22.854"	8.55"	0"
Invert 3										
Invert 4										
Invert 5										
Invert 6										
Invert 7										
Invert 8										

RIGHT-SIDE UP VIEW (int. dimensions)

UPSIDE-DOWN VIEW (int. dimensions)

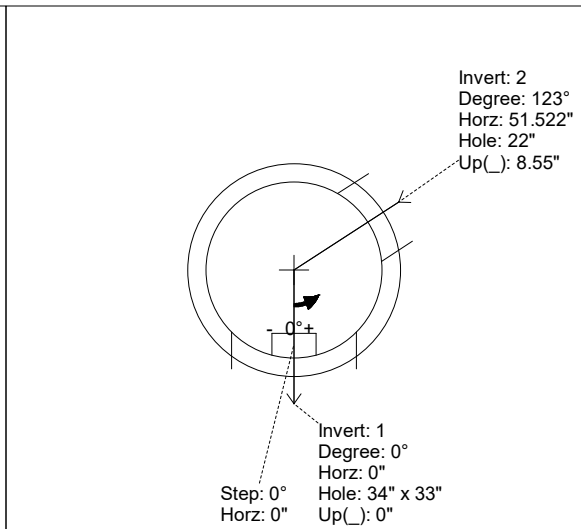
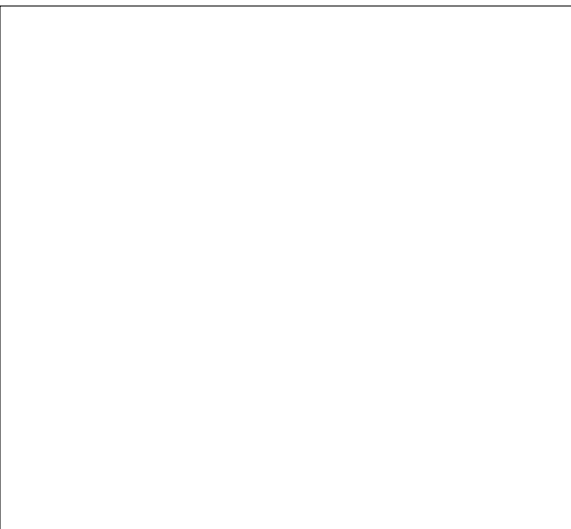
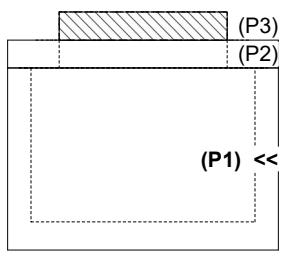

INSIDE WALL DIMENSIONS

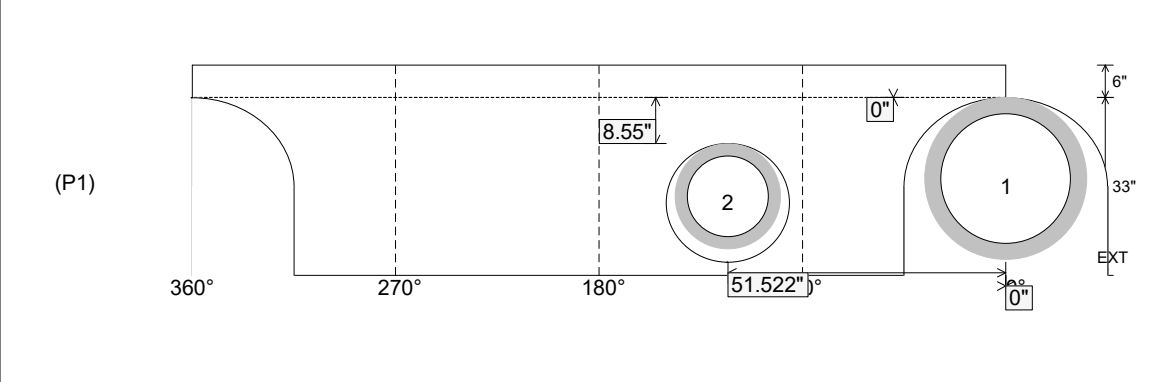

Coating (Int): Coating (Ext):	Seam Up: Flat Seam Dn: n/a	Wall Thickness: 5" Floor Height: 6"	Height (Int): 33" Height (Ext): 39"	Weight (Net): 3013 lb Volume (Net): 0.77cu.yd
----------------------------------	-------------------------------	--	--	--