

Job Name: 25-1951 - Speedway Site Design
Job Location: Horse Cave, KY
Contractor: Scotty's Contracting & Stone, LLC

PC: C. Goff
 TECH: J. Horsley - F
 Plant: 100



Structure ID: 1
 Spec: Storm
 Type: STM.MH
 Size: 48"

Rim: 580.31'
 Invert: 577.2'
 Rim to Invert: 3.11'

Sump: 33.96"
 Floor (Top): 574.37'
 Floor Height: 6"

Floor (Bot): 573.87'
 Overall Height: 6.417'
 Slack: 0.28"

Structure Notes:

- PER ASTM C478 SPECIFICATIONS.
 - CONCRETE = 4,000 PSI AT 28 DAYS.
 - NO INVERT CHANNEL.
 - CASTING BY I-CAST (HOE MCB-315-B FR./BAR GRATE).
- REINFORCING PER ASTM A615 (GRADE 60).
 - TOP SLAB (As .62) #5 BARS AT 6" C.C.E.W..
 - RISER/WALLS (As .12)
 - FLOOR (As .31) #5 BARS AT 12" C.C.E.W.

STRUCTURE SUMMARY:

- P3) 24" - CASTING HEIGHT - 7" 0 lb
 P2) 48" - MH FLAT TOP SPEC. HT. (6") w/24" Hole CC F/F - 6" 1102 lb
 P1) 48" - MH BASE Custom Ht F/n - 58" 4840 lb
 1) CASTING - HOE MCB-315-B Fr./Bar Grate 255 lb
 1) 48" - Conseal CS-102 1.00" 0 lb
 2) DOGHOUSE INVRTD - 26"x26" 0 lb
 2) MH Step ML-10-TDS-NCR - 10" 0 lb
- Structure Total: 6197 lb

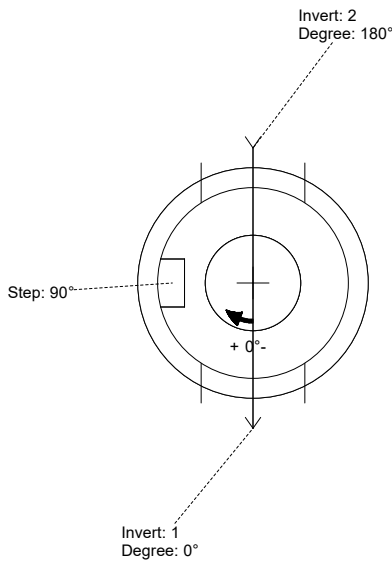

Position	Elev	Angle	Pipe	Pipe OD	Hole	Connector	Up (L)	Ref
Rim	580.31'							
Reducer								
Invert 1	577.2'	0°	18" RCP B WALL	23"	26" x 26"	DOGHOUSE INVRTD 26"x26"	31.46"	P1
Invert 2	577.2'	180°	18" RCP B WALL	23"	26" x 26"	DOGHOUSE INVRTD 26"x26"	31.46"	P1
Invert 3								
Invert 4								
Invert 5								
Invert 6								
Invert 7								
Invert 8								

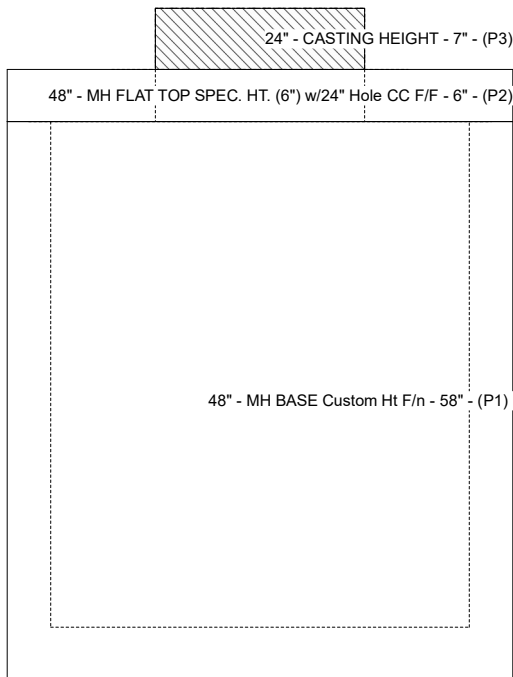

Cast (Int. Dim.) - Interior Dimensions

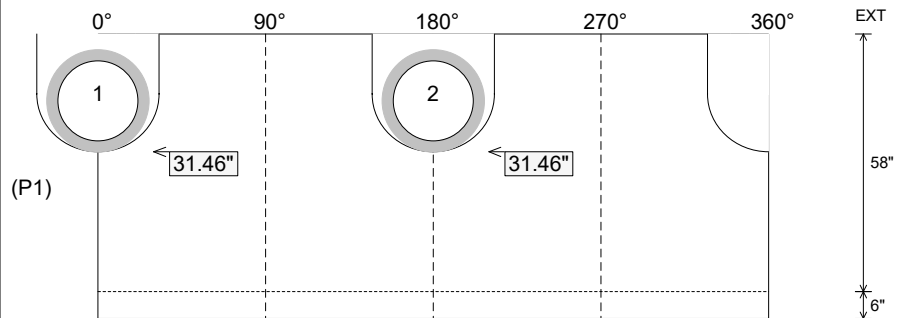

Submittal Drawing
 12/3/2025 8:03:42 AM

SUBMITTAL
 APPROVED BY: