

Job Name: 25-1922B Reynold's Farm
 Job Location: Goodlettsville, TN
 Contractor: Josh King Excavating

Plant: Beaver Dam
 4/8/2026 1:40:01 PM

Tech: S. Felletter
 PC: J. Jarvis



Structure ID: C0.3 ST-MH

P1 MH048BA72

MH BASE T/n

- P5) 24" - CASTING HEIGHT - 7"
- P4) 24" - GRADE RING F/F - 3"
- P3) 24" - GRADE RING F/F - 4"
- P2) 48" - ECC CONE w/ 24" HOLE F/G - 36"
- P1) 48" - MH BASE T/n - 72"
- 1) CASTING - JBS 1150 F/C STORM
- 1) 48" - Conseal CS-102 1.00"
- 2) Hole - 30
- 9) MH Step ML-10-TDS-NCR - 10"

0 lb
 202 lb
 270 lb
 3000 lb
 5728 lb
 250 lb
 0 lb
 0 lb
 0 lb

Structure Total: 9450 lb

- Structure Notes:**
1. PER ASTM C-478 SPECIFICATIONS
 2. CONCRETE: 4,000 PSI AT 28 DAYS
 3. REINFORCEMENT: PER ASTM A615
 4. STEPS AT 90 DEGREES
 5. JBS 1150 FRAME & COVER "STORM" SUPPLIED BY ICAST
- REMAKE OF BASE (P1) ONLY
 - ADDITION OF 3" GRADE RING (P4)
 - CASTING (P5), 4" GRADE RING (P3), & 36" CONE (P2) ALREADY ON SITE

Rim: 527' Rim to Invert: 10.16' Slack: 1.82" Sump: 1.9" Step Position: 90°

Position	Elev	Angle	Ext. (cw)	Pipe	Pipe OD	Connector	Hole	Horz Size	Up ()	Offset
Invert 1	516.84'	0°	0"	24" HDPE	27.8"	Hole 30	30"	32.406"	0"	0"
Invert 2	516.94'	210°	106.25"	24" HDPE	27.8"	Hole 30	30"	32.406"	1.25"	0"
Invert 3										
Invert 4										
Invert 5										
Invert 6										
Invert 7										
Invert 8										

RIGHT-SIDE UP VIEW (int. dimensions)

UPSIDE-DOWN VIEW (int. dimensions)

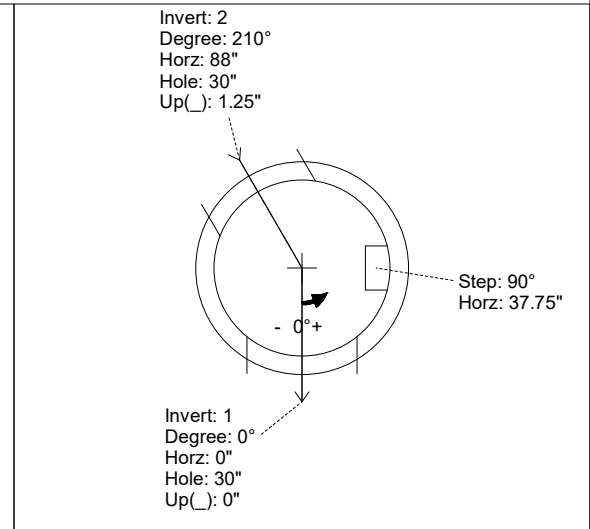
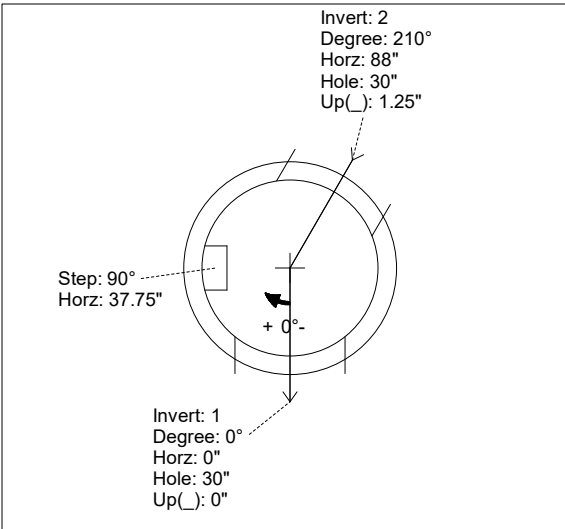
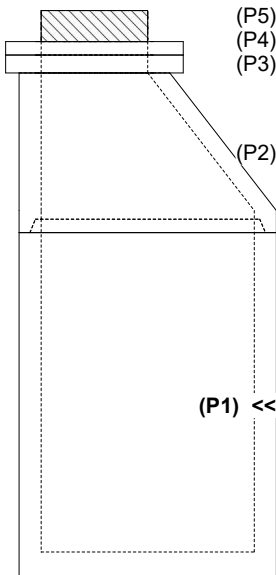

INSIDE WALL DIMENSIONS

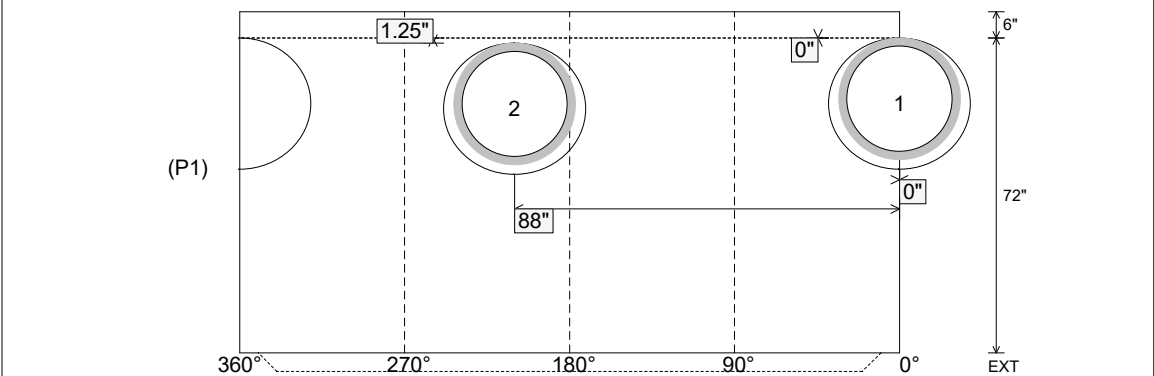

Coating (Int): Coating (Ext):	Seam Up: Tongue Seam Dn: n/a	Wall Thickness: 5" Floor Height: 6"	Height (Int): 72" Height (Ext): 78"	Weight (Net): 5728 lb Volume (Net): 1.46cu.yd
----------------------------------	---------------------------------	--	--	--