

Job Name: 25-1922 - Reynold's Farm
 Job Location: Goodlettsville, TN 37072
 Contractor: Josh King Excavation

Plant: Beaver Dam, KY
 1/8/2026 9:01:35 AM

Tech: K. Cardwell
 PC: J. Jarvis



Structure ID: C9.2

P2 MH048CN30

ECC CONE w/ 24" HOLE F/G

- P4) 24" - CASTING HEIGHT - 7"
- P3) 24" - GRADE RING F/F - 4"
- P2) 48" - ECC CONE w/ 24" HOLE F/G - 30"
- P1) 48" - MH BASE T/n - 24"
- 1) CASTING - JBS 1150 F/C STORM
- 1) 48" - Conseal CS-102 1.00"
- 2) Hole - 18
- 5) MH Step ML-10-TDS-NCR - 10"

0 lb
 270 lb
 2050 lb
 2789 lb
 250 lb
 0 lb
 0 lb
 0 lb

 5359 lb

Structure Total:

- Structure Notes:
1. PER ASTM C-478 SPECS
 2. CONCRETE: 4,000 PSI AT 28 DAYS
 3. REINFORCEMENT: PER ASTM A615
 4. STEPS AT 225 DEGREES
 5. JBS 1150 FRAME & COVER "STORM" SUPPLIED BY ICAST

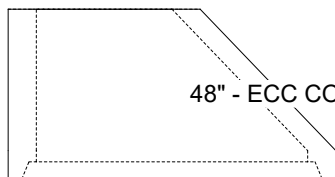
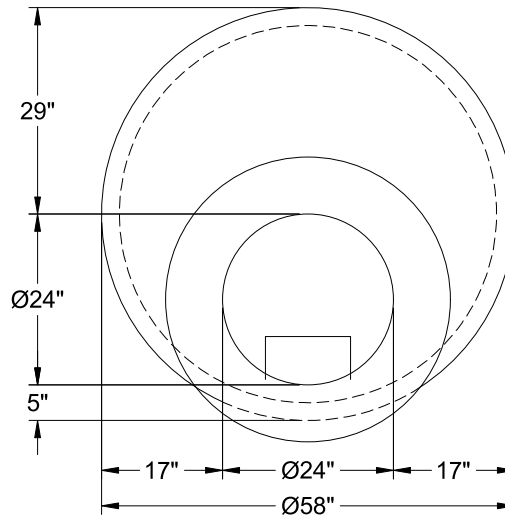

48" - ECC CONE w/ 24" HOLE F/G - 30" - (P2)

Coating (Int):
 Coating (Ext):

Seam Up: Flat
 Seam Dn: Groove

Wall Thickness: 5"

Height (Ext): 30"

Weight (Net): 2050 lb
 Volume (Net): 0.41cu.yd