

Job Name: 25-1922 - Reynold's Farm  
 Job Location: Goodlettsville, TN 37072  
 Contractor: Josh King Excavation

Plant: Beaver Dam, KY  
 1/8/2026 9:00:40 AM

Tech: K. Cardwell  
 PC: J. Jarvis



**Structure ID: C6**

**P1 MH048BAVF**

**MH BASE Custom Ht T/n**

- P3) 28" x 28" - CASTING HEIGHT - 7.50"
- P2) 48" - MH FLAT TOP w/28"x28" Hole F/G - 12"
- P1) 48" - MH BASE Custom Ht T/n - 41"
- 1) CASTING - JBS 3300 SET (F/G/H)
- 1) 48" - Conseal CS-102 1.00"
- 1) 28" x 28" - Conseal CS-102 1.00"
- 2) Hole - 32"
- 3) MH Step ML-10-TDS-NCR - 10"

0 lb  
 1368 lb  
 3468 lb  
 500 lb  
 0 lb  
 0 lb  
 0 lb  
 0 lb  
 0 lb  
 Structure Total: 5336 lb

- Structure Notes:**
1. PER ASTM C-478 SPECS
  2. CONCRETE: 4,000 PSI AT 28 DAYS
  3. REINFORCEMENT: PER ASTM A615
  4. STEPS AT 103 DEGREES
  5. JBS 3300 FRAME, GRATE, & CURB HOOD SUPPLIED BY ICAST

Rim: 525.9' Rim to Invert: 4.8' Slack: 0.1" Sump: 3" Step Position: 103°

| Position | Elev   | Angle | Ext. (cw) | Pipe           | Pipe OD | Connector | Hole | Horz Size | Up ( ) | Offset |
|----------|--------|-------|-----------|----------------|---------|-----------|------|-----------|--------|--------|
| Invert 1 | 521.1' | 0°    | 0"        | 24" RCP B WALL | 30"     | Hole 32   | 32"  | 35.027"   | 0"     | 0"     |
| Invert 2 | 521.2' | 193°  | 97.686"   | 24" RCP B WALL | 30"     | Hole 32   | 32"  | 35.027"   | 1.2"   | 0"     |
| Invert 3 |        |       |           |                |         |           |      |           |        |        |
| Invert 4 |        |       |           |                |         |           |      |           |        |        |
| Invert 5 |        |       |           |                |         |           |      |           |        |        |
| Invert 6 |        |       |           |                |         |           |      |           |        |        |
| Invert 7 |        |       |           |                |         |           |      |           |        |        |
| Invert 8 |        |       |           |                |         |           |      |           |        |        |

RIGHT-SIDE UP VIEW (int. dimensions)

UPSIDE-DOWN VIEW (int. dimensions)

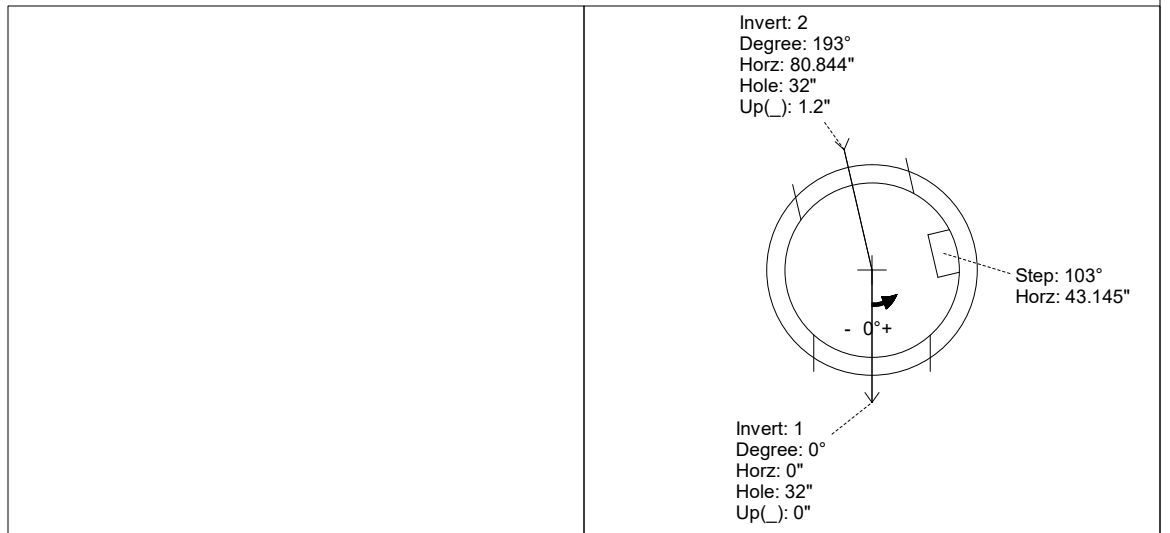
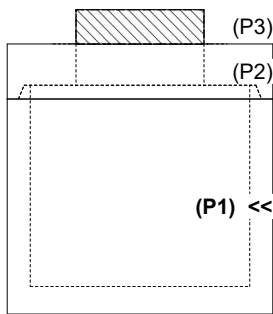

INSIDE WALL DIMENSIONS

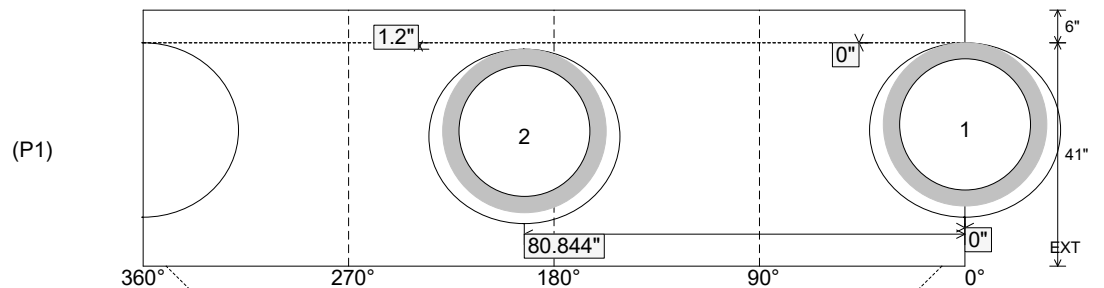

Coating (Int):  
 Coating (Ext):

Seam Up: Tongue  
 Seam Dn: n/a

Wall Thickness: 5"  
 Floor Height: 6"

Height (Int): 41"  
 Height (Ext): 47"

Weight (Net): 3468 lb  
 Volume (Net): 0.89cu.yd