

Job Name: 25-1922 - Reynold's Farm
 Job Location: Goodlettsville, TN 37072
 Contractor: Josh King Excavation

Plant: Beaver Dam, KY
 1/8/2026 9:01:36 AM

Tech: K. Cardwell
 PC: J. Jarvis



Structure ID: C11

P2 MH048LD12S

MH FLAT TOP w/30"x30" Hole F/G

- P4) 30" x 30" - CASTING HEIGHT - 8"
- P3) 30" x 30" - GRADE RING F/F - 3"
- P2) 48" - MH FLAT TOP w/30"x30" Hole F/G - 12"
- P1) 48" - MH BASE T/n - 60"
- 1) CASTING - JBS 3300 SET (F/G/H)
- 1) 48" - Conseal CS-102 1.00"
- 2) 30" x 30" - Conseal CS-102 1.00"
- 1) Hole - 22
- 1) Hole - 12
- 1) Hole - 18
- 5) MH Step ML-10-TDS-NCR - 10"

0 lb
 218 lb
 1350 lb
 5200 lb
 500 lb
 0 lb
 0 lb
 0 lb
 0 lb
 0 lb
 0 lb

 Structure Total: 7268 lb

- Structure Notes:
1. PER ASTM C-478 SPECS
 2. CONCRETE: 4,000 PSI AT 28 DAYS
 3. REINFORCEMENT: #4 BAR @ 10" C.C. E.W. (GRADE 60) - 2" MIN. REBAR CLEARANCE (TYP)
 4. STEPS AT 172 DEGREES
 5. JBS 3300 FRAME, GRATE, & CURB HOOD SUPPLIED BY ICAST
 6. LIFTERS: 4 EA. WRA016 CONAC WIRE ROPE ANCHORS FOR PLANT & FIELD HANDLING

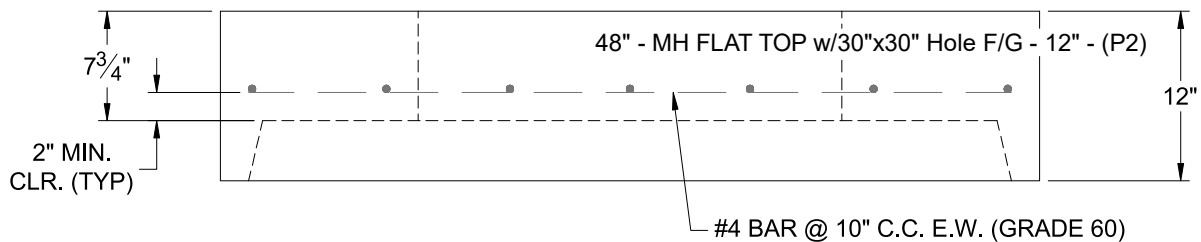
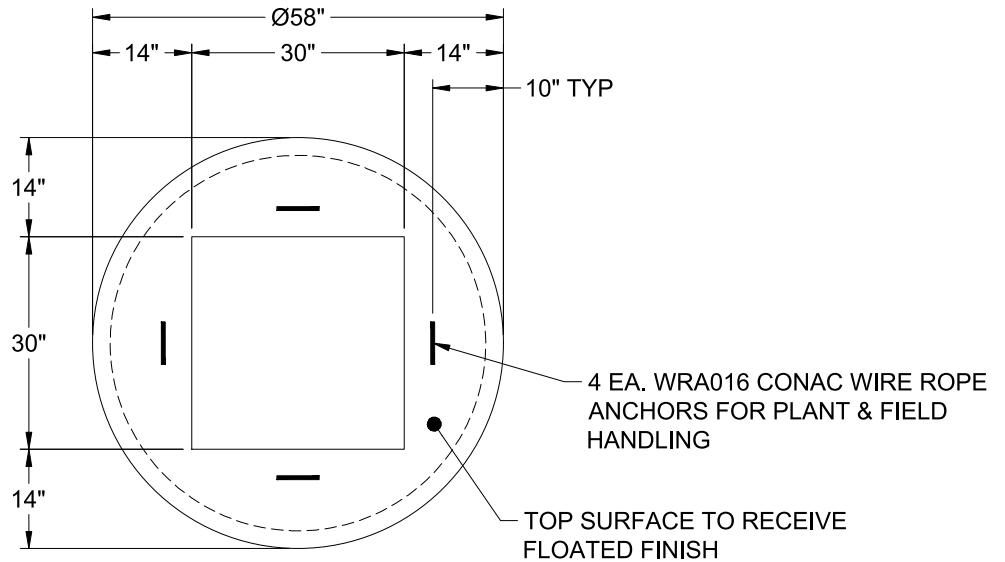

Coating (Int): Coating (Ext):	Seam Up: Flat Seam Dn: Groove	Wall Thickness: 5"	Height (Ext): 12"	Weight (Net): 1350 lb Volume (Net): 0.33cu.yd
----------------------------------	----------------------------------	--------------------	-------------------	--